



## Drive selection

### Technical data DC permanent magnet motors

#### Description

DC permanent magnet motors have a torque-speed characteristic with shunt characteristics. Thanks to a particular dimensioning of the armature winding (copper filling factor) there is only a low speed reduction under load.

The magnetic flux necessary to generate the torque is produced by permanent magnets.

A special field excitation winding and thus an element that would cause additional heat loss is not required. This means that the efficiency of a DC permanent magnet motor is better than the efficiency of a comparable field-wound DC motor. As permanent magnets are smaller than a comparable field winding, a DC permanent magnet motor is approximately one frame size smaller than a field-wound DC motor with the same rated power.



2

#### General data

Motor type	13.120.00.0.0.0
Enclosure	IP54
Thermal class (VDE 530)	F
Motor protection	Thermal contact (normally-closed contact)
Cooling	naturally ventilated
Temperature range	0 to +40 °C
Site altitude	Up to 1000 m a.m.s.l.
Electrical connection	Cable / terminal box Note options in the tables
Bearing	Deep-groove ball bearing
Operating mode (VDE 530)	S1

#### DC permanent magnet motor

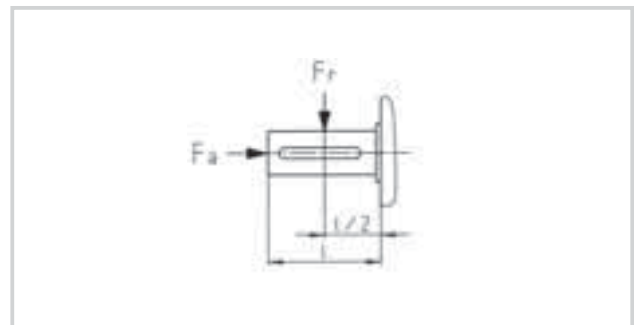

#### Rated data

Motor type	13.120.35		13.120.45		13.120.55		13.120.65		13.120.75	
Rated power (W)	55		110		200		370		540	600
Rated torque (Nm)	0.07		0.35		0.64		1.08		1.7	1.9
Rated armature voltage (V)	24	180	24	180	24	180	24	180	24	160
Rated current (A)	3.7	0.46	6.7	0.86	11.8	1.4	18.6	2.5	27	4.5
Max. demagnetisation current (A)	41	5	44	6	71	9	90	11.2	130	20
Armature resistance (Ω)	1.3	71	0.47	27.5	0.09	9.8	0.09	4.6	0.06	1.9
Armature inductance (mH)	1.8	98	1.4	52	0.54	31.5	0.4	25	9	0.26
Rated speed (rpm)	3000		3000		3000		3000		3000	
Moment of inertia (kgcm <sup>2</sup> )	0.458		1.03		3.8		10.69		16.8	
Max. radial force (N) $F_r$	220		320		340		580		570	
Max. axial force (N) $F_a$	200		280		280		330		460	



### Characteristics

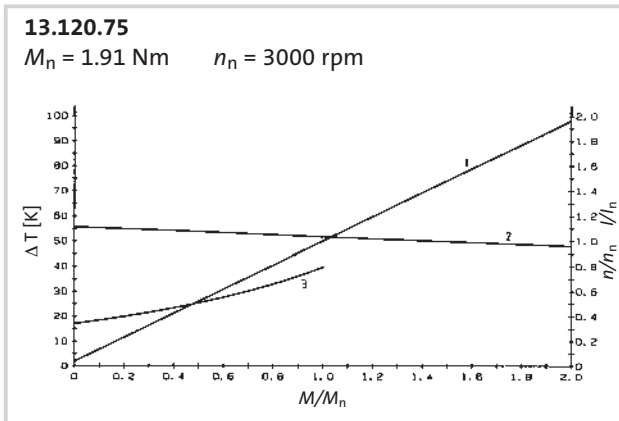
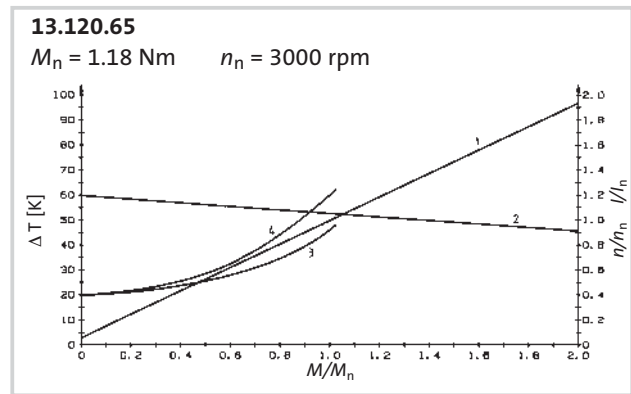
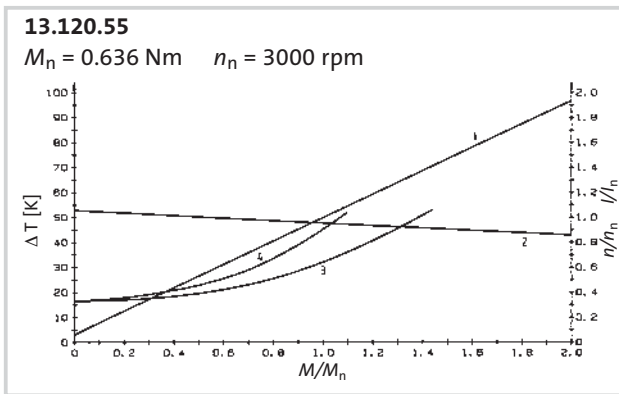
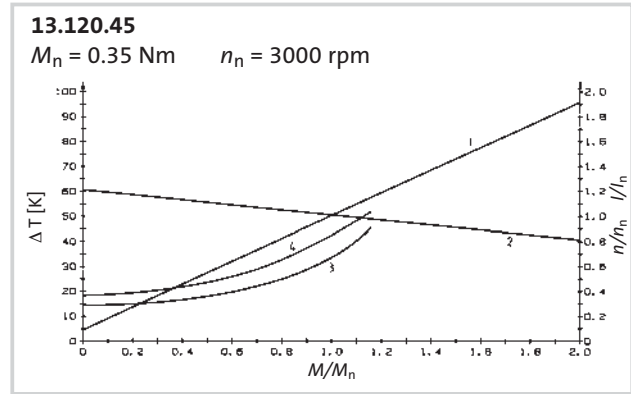
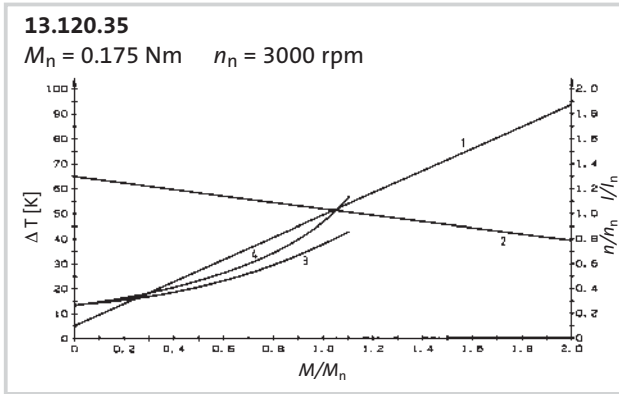

### Explanations

- 1: Armature current (mean value) as function of torque
- 2: Speed as function of torque at rated voltage
- 3: Housing temperature increase as function of torque at  $F_F = 1$  for 160 V and 180 V motors
- 4: As 3, for 24 V motors

$M/M_n$ ,  $I/I_n$ ,  $n/n_n$ : standardised values referred to the rated value

For a detailed dimensioning of the drives please consult your Lenze sales representative.



## Drive selection

### DC permanent magnet motors

Selection table Type 13.120.□□.□.□.□

Motor type	P <sub>N</sub> W	U V	n <sub>2</sub> rpm	M <sub>2</sub> Nm	Design A-side	Selection (tick as required)
13.120.35.0.3.0	55	24 or 180	3000	0.07	B3	
13.120.35.0.2.0					B14	
13.120.45.0.2.□	110	24 or 180	3000	0.35	B14	
13.120.45.1.2.□					IEC56 B14C80	
13.120.45.0.3.□					B3	
13.120.55.1.3.□	200	24 or 180	3000	0.64	IEC56 B3	
13.120.55.1.2.□					IEC56 B14C80	
13.120.55.1.2.□					IEC63 B14C90	
13.120.65.1.3.□	370	24 or 180	3000	1.08	IEC63 B3	
13.120.65.1.2.□					IEC63 B14C90	
13.120.65.1.2.□					IEC63 B14C120	
13.120.65.1.2.□					IEC71 B14C105	
13.120.75.1.3.□	540	24	3000	1.71	IEC71 B3	
13.120.75.1.2.□					IEC71 B14C105	
13.120.75.1.3.□	600	160	3000	1.91	IEC71 B3	
13.120.75.1.2.□					IEC71 B14C105	

#### Additional order information

<b>B-side design</b>	0 = no built-on accessories	
	1 = with spring-applied brake	frame size 45-75 only
	4 = with DC tacho	frame size 45-75 only
	5 = with AC tacho	frame size 45-75 only
	6 = for tacho attachment	frame size 45-75 only
	7 = for brake attachment	frame size 45-75 only
	<b>Rated armature voltage</b>	24 V
160 V		frame size 75 only
180 V		frame size 35-65 only
<b>Brake supply voltage</b>	24 V DC	
	205 V DC only with armature voltage of 160 V or 180 V	
<b>Electrical connection</b>	Cable	
	Terminal box with motor frame size 45-75 only	
<b>Position of electrical connection B3</b>		2 3 4 5
<b>Position of electrical connection B14</b>		2

Type code see pages 1-3 to 1-6.

Mounting position see cover fold-out.



### Selection table Type 13.12□.□□.□.□.□

Motor type	P <sub>N</sub> W	U V	n <sub>2</sub> rpm	M <sub>2</sub> Nm	Design A-side for gearbox attachment	Selection (tick as required)
13.120.35.9.2.0	55	24 or 180	3000	0.07	B14 for SPL42	
13.121.35.2.2.0					B14 for SSN25	
13.121.35.2.5.0					B3/B14 for SSN25	
13.121.45.3.2.□	110	24 or 180	3000	0.35	B14 for SSN31	
13.121.45.3.5.□					B3/B14 for SSN31	
13.121.55.3.2.□	200	24 or 180	3000	0.64	B14 for SSN31	
13.121.55.3.5.□					B3/B14 for SSN31	
13.121.65.5.2.□	370	24 or 180	3000	1.08	B14 for SSN40	
13.121.65.5.5.□					B3/B14 for SSN40	
13.121.75.5.2.□	540	24	3000	1.71	B14 for SSN40	
13.121.75.5.5.□					B3/B14 for SSN40	
13.121.75.5.2.□	600	160	3000	1.91	B14 for SSN40	
13.121.75.5.5.□					B3/B14 for SSN40	

### Additional order information

B-side design	0 = no built-on accessories	
	1 = with spring-applied brake	frame size 45-75 only
	4 = with DC tachometer	frame size 45-75 only
	5 = with AC tachometer	frame size 45-75 only
	6 = for tachometer attachment	frame size 45-75 only
	7 = for brake attachment	frame size 45-75 only
	Rated armature voltage	24 V
160 V		frame size 75 only
180 V		
Brake supply voltage	24 V DC	
	205 V DC only with armature voltage of 160 V or 180 V	
Electrical connection	Cable	
	Terminal box (not frame size 35)	
Position of electrical connection B3/B14		2 3 4 5
Position of electrical connection B14		2



# Drive selection

## DC permanent magnet motors

### Dimensions Type 13.120.□□.□.□.□

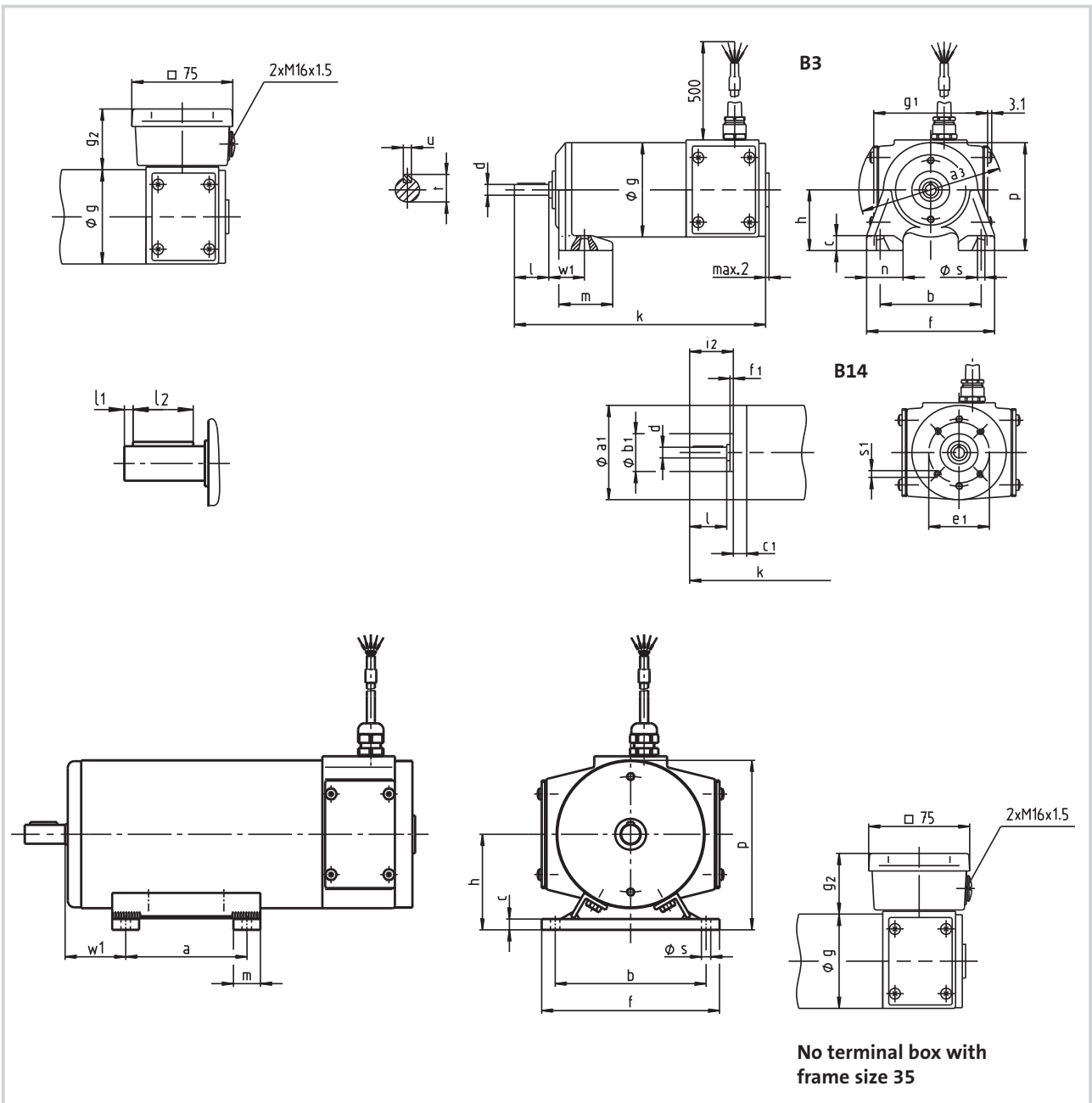



### Dimensions Type 13.120.□□.□.□.□

Motor type	Frame size	a	a <sub>1</sub>	a <sub>3</sub>	b j7	b <sub>1</sub>	c	c <sub>1</sub>	d	e <sub>1</sub>
13.120.35.0.□.□	B3	-	-	79	55	-	8	-	7h6	-
	B14		50.5		-	28	-	8		40
13.120.45.□.□.□	B3	-	-	107	75	-	11	-	8h6	-
	B14		69		-	28	-	12		45
	IEC56 B14C80		80		50	14	9k6	65		
13.120.55.□.□.□	IEC56 B3	-	-	115	90	-	13	-	9k6	-
	IEC56 B14C80		80		50	-	17	65		
	IEC63 B14C90		90		-	15	11k6	75		
	IEC63 B14C120		120		80	-	15	100		
13.120.65.□.□.□	IEC63 B3	-	-	140	100	-	15	-	11k6	-
	IEC63 B14C90		98		60	-	18.5	75		
	IEC63 B14C120		120		80	-	16.5	100		
	IEC71 B14C105		105		70	-	16.5	14k6	85	
13.120.75.□.□.□	IEC71 B3	90	-	154	112	-	8	-	14k6	-
	IEC71 B14C105	-	110		-	70	-	14.5		85

Motor type	f max.	f <sub>1</sub>	g	g <sub>1</sub>	g <sub>2</sub>	h	i <sub>2</sub>	k	l <sup>*)</sup>	l <sub>1</sub>	l <sub>2</sub>	m	n	p	s	s <sub>1</sub>	t	u	w <sub>1</sub>	Weight approx. kg				
13.120.35.0.□.□	71	-	54	62	-	32	-	172	31			24	20	59	5.5	-	-	-	18	1.4				
	-	2.5				-	33.5					-	-	-	M4	-								
13.120.45.□.□.□	96	-	70	84.5	45	45	-	186.5	29			40	28	80	5.5	-	-	-	23	2.4				
	-	2.5				-	32.5					-	-	-	M4	-								
							20					178	20	3.5	14	-	-	-	-		M5	10.2	3	-
13.120.55.□.□.□	112	-	80	95	45	56	-	213	20	3.5	14	60	34	96	6.5	-	10.2	3	36	3.7				
	-	2.5				-	20					-	-	-	M5	-								
	-	2.5				-	23					216	23	3	16	-	-	-	-		M5	12.5	4	-
	-	3				-										M6								
13.120.65.□.□.□	137	-	98	115	45	63	-	259.5	23	3	16	67	42	112	9	-	12.5	4	40	8				
	-	2.5				-	23					266.5	30	4	20	-					-	-	-	M5
	-	3				-										M6								
13.120.75.□.□.□	132	-	110	132	46	71	-	288	30	4	20	20		126	7	-	16	5	45	10.2				
	-	2.5				-	30					-	-	-	-	M6					-			

\*) Motors 13.120.35 / 45 do not have a shaft collar.

Dimensions in mm