

# AEM - Three-phase asynchronous motors - Catalogue 2010

**Contents** (for selecting, please click on text)

- 0**        **General**
  
- 1**        **Technical explanations**
- 1.1        Power range
- 1.2        Type code of AEM Motors
  
- 1.3**       **Mechanical design**
- 1.3.1      Construction
- 1.3.2      Types of construction acc. to DIN EN 60034 / part 7
- 1.3.3      Degrees of protection acc. to DIN EN 60034 / part 5
- 1.3.4      Cooling methods acc. to DIN EN 60034 / part 6
- 1.3.5      Bearings
- 1.3.6      Shaft ends
- 1.3.7      Rotor design
- 1.3.8      Vibration characteristics
- 1.3.9      Noises
- 1.3.10     Ambient conditions
- 1.3.11     Belt drive
  
- 1.4**       **Electrical design**
- 1.4.1      Voltage and frequency
- 1.4.2      Output and overload capability
- 1.4.3      Speed and speed adjustment
- 1.4.4      Types of duty and switching frequency
- 1.4.5      Insulation
- 1.4.6      Operation in the frequency inverter (FI-mode)
  
- 1.5**       **Motor specifications**
- 1.5.1      Pole changing motors
- 1.5.2      Medium voltage motors
- 1.5.3      Thermal protection devices
- 1.5.4      Anti-condensation heater
- 1.5.5      Excavator application
- 1.5.6      Special rotors
- 1.5.7      Partial load operation for slip-ring motors
- 1.5.8      Change over to residual voltage
- 1.5.9      Asynchronous generator
  
- 2**        **Planning and design guidelines**
- 2.1        General project planning and design guidelines
- 2.2        Characteristic counter-torques
- 2.3        Planning and design with respect to starting performance
- 2.4        Drive motors with free-floating belt pulley
- 2.4.1      Calculation of the radial force on the belt pulley
- 2.4.2      Calculation of mass force
- 2.4.3      Calculation of the actual radial force that exists
- 2.4.4      Attachment of belt pulley
- 2.4.5      Direction and size of existing forces

- 2.5 Enquiries / Order data
- 2.6 Dimensions
- 2.7 Symbols and conversions

### **3 Power range and dimensions**

#### **3.1 Series R (surface ventilated)**

- 3.1.1 Three-phase asynchronous motor with squirrel-cage rotor, shaft height 355 mm
- 3.1.2 Three-phase asynchronous motor with squirrel-cage rotor
  - 3.1.2.1 Shaft height 400 mm, series R
  - 3.1.2.2 Shaft height 400 mm, series 2R
- 3.1.3 Three-phase asynchronous motor with squirrel-cage rotor, shaft height 450 mm
- 3.1.4 Three-phase asynchronous motor with squirrel-cage rotor, shaft height 500 mm
- 3.1.5 Three-phase asynchronous motor with welded stator, shaft height 560 mm
- 3.1.6 Three-phase asynchronous motor with slip-ring rotor, shaft height 355 mm
- 3.1.7 Three-phase asynchronous motor with slip-ring rotor, shaft height 400 mm
- 3.1.8 Three-phase asynchronous motor with slip-ring rotor, shaft height 450 mm
- 3.1.9 Three-phase asynchronous motor with slip-ring rotor, shaft height 500 mm
- 3.1.10 Three-phase asynchronous motor with slip-ring rotor - crane duty, shaft height 355 mm
- 3.1.11 Three-phase asynchronous motor with slip-ring rotor - crane duty, shaft height 400 mm
- 3.1.12 Three-phase asynchronous motor with slip-ring rotor - crane duty, shaft height 450 mm
- 3.1.13 Three-phase asynchronous motor with slip-ring rotor - crane duty, shaft height 500 mm

#### **3.2 Series A (open-circuit ventilated)**

- 3.2.1 Three-phase asynchronous motor with squirrel-cage rotor, shaft height 315 mm
- 3.2.2 Three-phase asynchronous motor with squirrel-cage rotor, shaft height 355 mm
- 3.2.3 Three-phase asynchronous motor with squirrel-cage rotor, shaft height 400 mm
- 3.2.4 Three-phase asynchronous motor with squirrel-cage rotor, shaft height 450 mm
- 3.2.5 Three-phase asynchronous motor with squirrel-cage rotor, shaft height 500 mm
- 3.2.6 Three-phase asynchronous motor with squirrel-cage rotor, shaft height 560 mm
- 3.2.7 Three-phase asynchronous motor with slip-ring rotor, shaft height 315 mm
- 3.2.8 Three-phase asynchronous motor with slip-ring rotor, shaft height 355 mm
- 3.2.9 Three-phase asynchronous motor with slip-ring rotor, shaft height 400 mm
- 3.2.10 Three-phase asynchronous motor with slip-ring rotor, shaft height 450 mm
- 3.2.11 Three-phase asynchronous motor with slip-ring rotor, shaft height 500 mm
- 3.2.12 Three-phase asynchronous motor with slip-ring rotor, shaft height 560 mm

#### **3.3 Series U (tube-cooled)**

- 3.3.1 Three-phase asynchronous motor with squirrel-cage rotor, shaft height 630 mm
- 3.3.2 Three-phase asynchronous motor with squirrel-cage rotor, shaft height 710 mm
- 3.3.3 Three-phase asynchronous motor with slip-ring rotor, shaft height 630 mm
- 3.3.4 Three-phase asynchronous motor with slip-ring rotor, shaft height 710 mm

#### **3.4 Series W (water-jacketed cooled)**

- 3.4.1 Three-phase asynchronous motor with squirrel-cage rotor, shaft height 315 mm
- 3.4.2 Three-phase asynchronous motor with squirrel-cage rotor, shaft height 355 mm
- 3.4.3 Three-phase asynchronous motor with squirrel-cage rotor, shaft height 400 mm
- 3.4.4 Three-phase asynchronous motor with squirrel-cage rotor, shaft height 450 mm
- 3.4.5 Three-phase asynchronous motor with squirrel-cage rotor, shaft height 500 mm
- 3.4.6 Three-phase asynchronous motor with squirrel-cage rotor, shaft height 560 mm

### **4 Delivery and performance programme**

## 0 General

Anhaltische Elektromotorenwerk Dessau GmbH (AEM) Three-phase Asynchronous Motors with a rated output range of 110 to 3500 kW (related to 1500 rpm and 400 V), available in various sizes, degrees of protection and cooling methods have, among other things, the following characteristic features:

- Self-contained series of slip-ring and squirrel-cage motors in the pole number range of  $2p = 2$  to 12 for a large number of drive cases,
- Standardized dimensions and parameters according to international and national regulations (IEC 60034, IEC 60072, DIN EN 60034),
- Design as a medium voltage motor up to a maximum of 6.6 kV possible,
- Special design for drive cases with free-floating belt pulley,
- Speed adjustment of squirrel-cage motors through with frequency inverter or models with pole-changing winding,
- Special designs for special ambient, fitting and operating conditions (e.g. ship version, excavator version, climatic protection etc.),
- Customer-specific design and electrical adjustment of the motors to special use conditions (e.g. rolling mill applications),
- Special motor series of slip-ring motors for crane duty operation.

**Please note that we continuously develop and improve our products. We retain the right to make changes in the interest of technical progress. All the technical informations in this document is only binding with our written confirmation.**

## 1 Technical explanations

### 1.1 Power range of the AEM Three-phase Asynchronous Motors

Series	Shaft height [mm]	Degree of protection acc. to DIN EN 60034-5	Cooling method acc. to DIN EN 60034-6	Explanation
AH/AK, AS	315 <sup>1)</sup> 355 400 450 500 560	IP 23 IP 55	IC 01 IC 06 IC 81W(IC 86W) IC 666 (IC 616)	open-circuit ventilated forced ventilated built-on air-water cooler air-air heat exchanger
RH/RK, RS 2RH/2RK <sup>2)</sup>	355 400 450 500 560 <sup>3)</sup>	IP 55	IC 411 IC 416	rib-cooled / surface ventilated forced ventilated
UH/UK, US	630 710	IP 55	IC 511	tube-cooled
WH/WK	315 355 400 450 500 560	IP 55	IC 71W	water-jacketed cooled

1) for low voltage only

2) shaft height 400 only

3) RH/RK only

## 1.2 Type code of AEM Three-phase Asynchronous Motors

The type designation is made up of letters and digits, which describe the respective characteristic properties.

### Type code series A, R, U, W and T

Generation (uprating)	2			
Rib-cooled asynchronous motor Open-circuit ventilated asynchronous motor Tube-cooled asynchronous motor Water-jacketed cooled asynchronous motor Submersible motors (on request only)		R A U W T		
Deep-bar (squirrel-cage) rotor Double-cage (squirrel-cage) rotor Slip-ring rotor			H K S	
Special conditions: - Suitable for belt drive with exposed belt pulley - Slip-ring motor with brush lifting device - Crane motor (for RS only)				R B K
Shaft height [mm] acc. to IEC 60034	315 to 710			
Code letter for length of iron lamination		S M L		
Code letter for modified length of iron lamination			A B L	
Pole number range	2p = 2 (Shaft height 315 to 450) 2p = 4 to 12 (Shaft height 315 to 710) (2p ≥ 14 on request)			
Example	<b>RHR 400 MA4</b>			

## 1.3 Mechanical design

### 1.3.1 Construction

The basic design of the housing and end shield of the open-circuit air-cooled series A motors have a shaft height of 315 mm made of grey cast iron. Welded stators are always used from shaft height 355 mm. Due to the complete welded steel design, a large range of special design dimension requirements (e.g. base hole spacings, shaft dimensions etc.). The IP 23 degree of protection available for this series can be increased to IP 55 (section 1.3.3) through a built on air-water cooler or air-air heat exchanger.

The R series ribbed housing with moulded base and both end shields is made from grey cast iron. The terminal box is located on the D-side of the stator back and is mounted so that it can be rotated by 180°, therefore the motor can be connected from the right or left, as required. Side mounting of the terminal box is possible on request. In case of unusual mechanical loads, e.g. in rolling mill operation, a special version with welded ribbed stator and end shields is possible.

The tube-cooled type U series motors essentially consist of a stable welded construction for use under even the hardest conditions. The terminal box is mounted on the rear of the stator and can be rotated by 180°. In a special embodiment, the stator terminal box (and the rotor terminal box too) can be mounted laterally.

Series W three-phase asynchronous motors (i.e. type WH, WK, WHR squirrel-cage motors) are water-jacketed cooled motors which are manufactured for the following shaft heights 315, 355, 400, 450, 500 and 560 mm. The stator frame (with feet) is designed as a steel-welded structure and the end shields are made of (grey) cast iron. In a special embodiment, the terminal box can be mounted laterally.

### 1.3.2 Types of construction according to DIN EN 60034 / part 7

The motors are produced in the basic construction type IM 1001 (IM B3) according to DIN EN 60034 / part 7 or are available as modifications in the construction types IM 1002, IM 1003, IM 1004 (corresponds to construction type B3 with one or two cylindrical or conical shaft ends), IM 1011 (IM V5) and IM 3011 (IM V1). Other construction types are possible on request.

Assignment of the flange and shaft size of the vertical design (IM V1) is given in the following table, other shaft and flange dimensions are available on request:

Shaft height	Shaft dimensions		Flange dimensions		
	D <sub>Shaft</sub> [mm]	L <sub>Shaft</sub> [mm]	D <sub>External</sub> [mm]	D <sub>Drilled holes</sub> [mm]	D <sub>Locator</sub> [mm]
315	90	170	660	600	550
355	100	210	800	740	680
400	110	210	1000	940	880
450	120	210	1000	940	880
500	130	250	1150	1080	1000

### 1.3.3 Degrees of protection according to DIN EN 60034 / part 5

Basic design series A motors are designed with degree of protection IP 23. It ensures protection against contact with moving, live parts and against the penetration of solid bodies with a diameter of 12.5 mm plus and against the harmful effect of water, which falls as splashing water from all sides at an angle of up to 60° to the vertical.

Series A motors can be produced as a special design with a built-on air-water heat exchanger (cooling method IC 81W) or with a built-on air-air heat exchanger (cooling method IC 666). As a result, degree of protection IP 55 can be achieved.

R, U and W series motors are basically designed with degree of protection IP 55. They therefore provide complete protection against contact, harmful internal dust deposits and the effects of hose-water from any direction.

Degree of protection IP 56 or higher is available on request!

### **1.3.4 Cooling methods according to DIN EN 60034 / part 6**

Ventilation of the series A motors (open-circuit ventilated) corresponds to cooling method IC 01 according to DIN EN 60034 part 6. The end shields are designed so that effective open-circuit cooling is achieved. Special designs of series A motors with cooling method IC 81W (resp. IC 86W) with built-on air-water cooler as a double tube circuit cooler and IC 666 (resp. IC 616) with built-on air-air heat exchanger are available on request.

Series R motors (rib-cooled / surface ventilated) are designed according to cooling method IC 411. On the one hand the heat exchange takes place via the laminated stator core on the ribbed housing and on the other hand, via an internal air circuit, which transfers part of the heat losses incurred to the hollow ribs, which are designed as cooling ducts.

In the series U motors the cooling is achieved through tube-cooling according to cooling method IC 511, i.e. by an internal air-air heat exchanger. This is achieved constructively by introducing ventilation tubes in the stator housing.

The motors are fitted with cast aluminium radial fans or welded sheet metal fans. For operation with a frequency inverter, depending on the type of counter-torque and speed adjustment range required, a separately driven fan can be fitted (in case of the cooling method IC 06, IC 416 and IC 86W only).

Series W motors are operating with water-jacketed cooling acc. to cooling method IC 71W. The water circulation for the motor takes place within an inner jacket. Externally fixed channels serve the installation and/or cooling of the inner air circulation. As standard, the stator terminal boxes and the connection threads for inflowing/outflowing water are arranged on the backs of the stator.

### **1.3.5 Bearings**

Spring-loaded deep-groove ball bearings are used for the standard design series A, R and W motors, for the series U motors are used cylindrical roller bearings. Special bearings are used for special designs with increased radial loading, e.g. for belt drive, vertical type of construction or similar (angular-contact ball bearings, four-point bearings etc., as double bearings in combination with deep-groove ball bearings mostly). It is possible too to install self greased sleeve bearings on request.

The respective binding bearings fitted are given in the motor documentation.

The bearings are equipped with grease volume regulators and re-greasing fittings.

The re-greasing intervals required are given on the respective additional plates on the bearing points and the motor documentation.

### **1.3.6 Shaft ends**

The shaft ends are produced cylindrically according to DIN EN 50347 / DIN IEC 60072-2 and with feather key grooves according to DIN 6885 in half-wedge balancing.

A second cylindrical shaft end or the version with one or two conical shaft ends can be provided on request.

### **1.3.7 Rotor design**

Series A, R, U and W motors can be supplied as deep-bar or as double-cage rotors depending on the drive case. All cages are of bar design and are fitted with welded or soldered end rings.

Motors with a slip-ring rotor have slip rings on the N side and carbon brushes that are in permanent contact. The slip-ring compartment is accessible through servicing openings.

Motors with slip-ring rotors in which the sliding contact is to remain wear free in continuous operation are equipped with a brush lifting device (BAV), which enables the brushes to be raised with simultaneous short-circuiting of the slip rings after the startup (types of motor ASB, RSB, USB). Actuation is manual using a lever or remote controlled with a motor drive.

### **1.3.8 Vibrations characteristics**

The basic design motors correspond to the vibration severity grade A acc. to DIN EN 60034-14 respectively IEC 60034-14. Motors for vibration severity grade B are available on request.

Measuring nipples for shock pulse detectors (SPM nipples) can be fitted for monitoring the bearings based on vibration analysis.

### 1.3.9 Noises

The limit values of DIN EN 60034 part 9 are complied with respect to mechanically and electrically caused noises.

Guideline values for the sound power level of the motors can be given with a tolerance of + 3 dB(A). Noise reduction, e.g. by fitting a noise-insulating cover or by using optimised special fans is available on request.

If operated at variable frequencies and /or voltages (e.g. frequency inverter), an increase in noise level by at least 3 to 5 dB(A) compared to mains operation is to be expected.

### 1.3.10 Ambient conditions

When designing the three-phase asynchronous motors and calculating the rated power in the tables of this catalogue, an ambient temperature (or coolant temperature) of - 30 °C to + 40 °C and an installation height of up to max. 1000 m above sea level is assumed. In case of application cases above 40 °C and over 1000 m installation height the performance must be reduced in accordance with the following table:

Ambient temperature [°C]	30	35	40	45	50	55	60
Height [m] above sea level							
to 1000	1.07	1.04	1.00	0.96	0.92	0.86	0.79
from 1000 to 2000	1.04	1.00	0.96	0.92	0.86	0.79	0.71
from 2000 to 3000	1.00	0.96	0.92	0.86	0.79	0.71	0.64
from 3000 to 4000	0.96	0.92	0.86	0.79	0.71	0.64	0.57

In case of motors with water cooling (water-jacked cooling and double tube circuit cooler) the power range is dependent too on the actual temperature for the inflowing water.

### 1.3.11 Belt drive

For torque transmission with free-floating belt drive the design notes (section 2.4) must always be observed, especially with respect to the permissible radial forces.

## 1.4 Electrical design

### 1.4.1 Voltage and frequency

In the voltage range from 220 V to 6600 V, the motors are designed for the standardized voltages according to DIN IEC 60038.

Customer-specific design is available on request.

### 1.4.2 Output and overload capability

The rated outputs specified in the catalogue are the values available at the shaft end. They apply to the ambient conditions defined in section 1.3.10 (40 °C, 1000 m above sea level only) and a main frequency of 50 Hz and a rated voltage.

In accordance with DIN EN 60034 part 1, motors with a rated voltage and rated frequency can be overloaded at rated-load operating temperature conditions for approx. 2 minutes with 1.5 times the rated current. They also ensure 15 seconds long loading with 1.6 times the nominal moment - without stalling or a drop in speed.

### 1.4.3 Speed and speed adjustment

The rated speed will be reached when the motor is running at a rated output, rated voltage and rated frequency. It differs from the synchronous speed  $n_s$  by a differential speed corresponding to the rated slip  $s$ .

Pole number 2p		2	4	6	8	10	12
$n_s$ [rpm]	50 Hz	3000	1500	1000	750	600	500
$n_s$ [rpm]	60 Hz	3600	1800	1200	900	720	600

The motors are also available for a rated frequency of 60 Hz. They can be operated at 1.2 times the rated power if the voltage is raised by 20 %.

For example, a change in speed required by the working process can be achieved by using pole-changing windings (section 1.5.1).

A continuous, mainly loss-free speed adjustment over wide speed ranges can be realised by altering the stator voltage and the frequency with frequency inverters (section 1.4.6).

### 1.4.4 Type of duty and switching frequency

All motors in this catalogue are intended for S1 type of duty (continuous operation) according to DIN EN 60034 part 1. The choice of motors for types of duty S2 to S10 is made taking into account the respective required operating conditions and exclusively on request.

Consideration of the types of duty and switching frequency for continuous operation S1 is extremely important, taking into consideration the number of switches per unit of time (hour, day) and the respective thermal operating condition of the machine especially regarding the service life of the winding.

### 1.4.5 Insulation

All windings are designed with insulating materials and wire insulation in the insulation class F as a standard. At the request of the customer, design in the insulation class H is possible.

Taking into consideration the voltage level and the special operating conditions (e.g. inverter operation, high switching frequency), enamel-insulated, glass filament insulated or mica film-insulated wires are used as a fed-in or former winding. These windings achieve high electrical and mechanical strength through vacuum pressure impregnation (VPI) with a polyester imide resin.

#### **1.4.6 Operation in the frequency inverter (FI mode)**

Adjusting the speed of three-phase asynchronous motors by varying the voltage and frequency has become more and more importance in recent years. The planning and design and operation of inverter-fed squirrel-cage motors require that the manufacturer notes several special features, which do not occur during operation in the fixed grid.

Principally, the FI-operation design motors are protected against the non-sinus shaped current and voltage loads by an increased winding insulation as well as against shaft voltages and bearing currents that occur with an insulated seat of bearing.

The type is selected on request according to the customer requirements (type of working machine, type of inverter, adjustable speed range etc.). Above all, attention must be paid to reducing the rated power by approx. 5 up to maximum 12.5 % due to additional losses.

In case of worsening of self-ventilation with reducing speed, if necessary, the motors are cooled by an axial separately driven fan according to the thermal design.

Additional losses resulting during inverter operation, the reduced applied moment capacity in the field-weakening range and the increase in motor noise (e.g. due to harmonics) should be taken into consideration when planning the drive.

## **1.5 Motor specifications**

### **1.5.1 Pole changing motors**

Squirrel-cage motors for low voltage can be designed as pole-changing motors. Motors must always be started through polar pole sequence. On request, the lowest speed stage can be provided for star-delta starting.

### **1.5.2 Medium voltage motors (up to 6600 V )**

In the rated voltage range of 1000 to 6600 V (medium voltage) squirrel-cage and slip-ring motors with a large range of shaft height and pole numbers are available.

The structure of the insulation complies with insulation class F, whereby the windings are made of pre-formed coils, which are wound with high-quality mica film bands and are impregnated in modern VPI plant. These motors are designed on request.

### **1.5.3 Thermal protection devices**

The motors can be equipped with PTC sensors and constant temperature monitoring with Pt100 sensors to protect the stator winding against thermal overload (e.g. increased cooling air temperature, obstructed cooling, severe load changes, switching operation or phase failure). If required the bearing temperature can also be monitored with Pt100 sensors.

### **1.5.4 Anti-condensation heater**

Motors intended for outdoor use, marine application or for use in tropical regions an installation of anti-condensation heaters is advisable to ensure that condensate cannot collect during extended stoppages.

To achieve this, heating tapes are fitted in the stator winding heads or on the pressure rings (connected voltage 230 V or another voltage on request).

### **1.5.5 Excavator application**

The motors on offer in this catalogue can also be supplied for excavators. This version is appropriately designed to take into consideration the increased vibration stresses in excavators and similar plant.

### **1.5.6 Special rotors**

Squirrel-cage motors can be supplied with special rotors for severe starting conditions. However, to do this the precise path of the counter-torque of the machine to be driven, the external moment of inertia and the number of starts (switching frequency) must be known.

### **1.5.7 Partial load operation for slip-ring motors**

Since normal slip-ring motors are designed for 70 to 100 % of rated output, a special version is required for loads under 70 % (partial load operation).

### **1.5.8 Change over to residual voltage**

When switching a motor back on, (primarily when power blocks are changed in power stations), under unfavourable condition, e.g. in case of phase opposition, transient phenomena with partially significant electro-dynamic forces affect the conducting components of the motor and can have a detrimental effect on the service life of the winding and thus motor.

If residual voltages of over 60 % are expected, we can provide a special design motor with increased winding overhang strength recovery.

### **1.5.9 Asynchronous generator**

An asynchronous machine with squirrel-cage rotor works as a generator and has active power output if it is operated hyper-synchronously. It requires a reactive power for excitation, either from the mains (mains-held) or from a capacitor battery (isolated operation).

The application for asynchronous generators primarily covers small hydro-electric power stations, as here the robust and cost effective design of asynchronous machines is particularly noticeable. The selection should be made after consulting the manufacturer only.

## **2 Planning and design guidelines**

### **2.1 General project planning and design guidelines**

The main factors relevant when selecting the motor are the type of machine to be driven (i.e. counter-torque) as well as the ambient conditions at the place of installation.

Slip-ring rotors can be used universally, especially for high starting torques (e.g. cranes, conveyor belts, mills etc.) without high starting currents being induced in the mains. Speed adjustment is possible (however, is subjected to losses) by regulating resistors (automatic starters).

Slip-ring motors are started up with motor starters (e.g. oil-cooled starters, electrolytic starters), which are selected according to the rotor data (rotor current and rotor open-circuit voltage) as well as the starting load factor (dependent on the type of machine to be driven).

Deep-bar rotors are suitable as universal drive motors for a wide range of applications (e.g. pumps, converters). This type of rotor should be used particularly for starts with high external moments of inertia (e.g. blowers, fans).

Double squirrel cage rotors are preferentially used if a high start up moment is required (e.g. compressors) or if difficult starting conditions require particular adjustment of the rotor configuration.

Both types of squirrel cage rotors are suitable for direct switching, for switching on with starting transformer or soft starters as well as for switching on via the star-delta start.

However, for star-delta start it must be noted that in the star stage, both the starting current and the torque must be reduced to approx. 30 % of the value for direct switching. Switching over from star to delta should therefore only be carried out close to the nominal speed, to avoid the otherwise still relatively high starting currents.

### **2.2 Characteristic counter-torques**

The characteristic curve of counter-torques of drives can generally be represented by three basic forms:

- Counter-torque is constant over the speed, e.g. in lifting gears, winches, conveyor belts and compressors;
- Counter-torque increases linearly with the speed, e.g. in generators and frequency converters;
- Counter-torque increases with the potency of the speed, e.g. fans, pumps.

Precise knowledge of the counter-torque of the working machine to be driven is very important when selecting the motor, as the design point (i.e. the working point on the characteristic curve) and starting method are determined according to the load characteristics. At the same time, it must be noted that the resulting characteristic curve results from superimposing several characteristic curves and can therefore vary between broad limits according to the typical special constructive and process features.

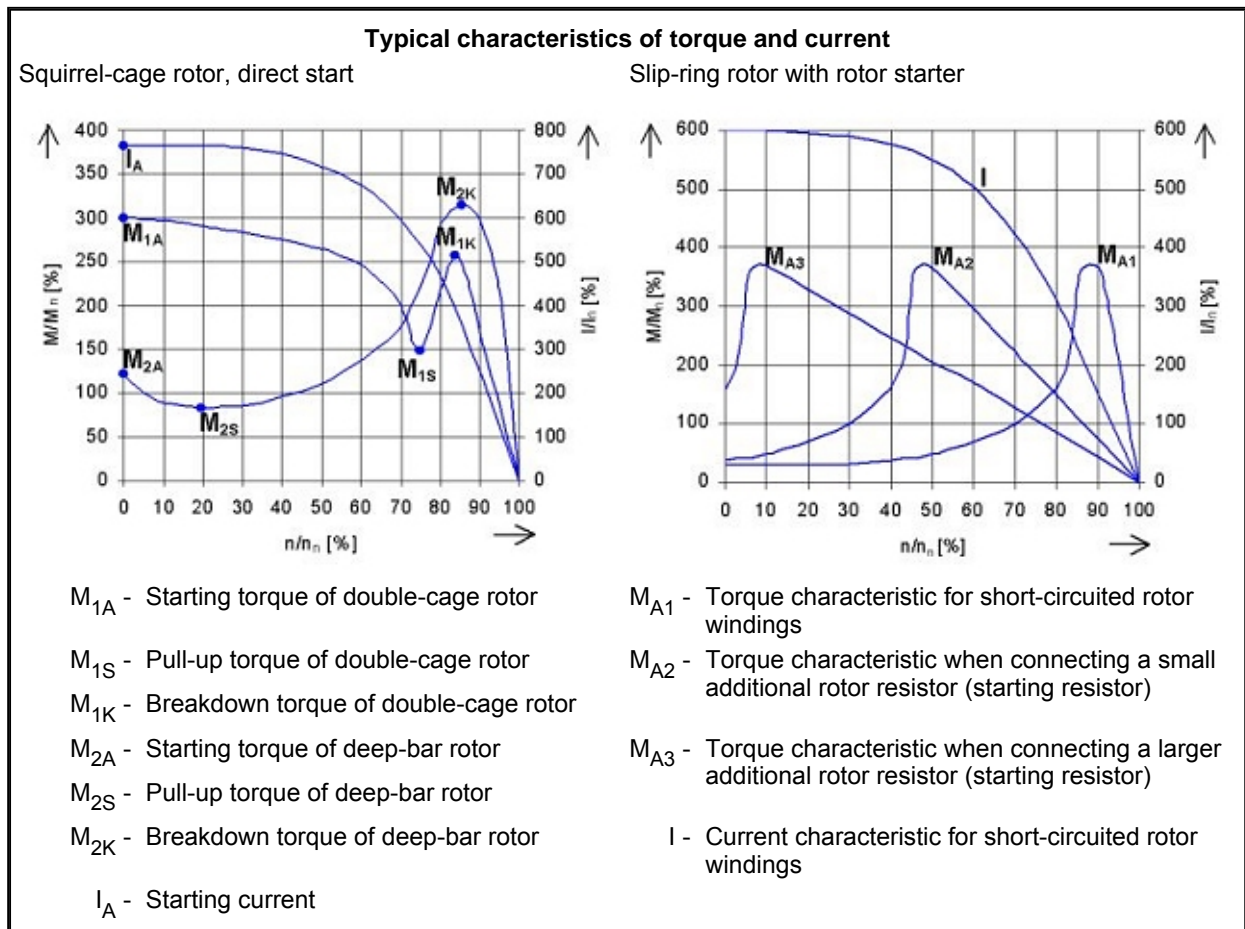

### 2.3 Planning and design with respect to starting performance

According to section 1.4.4 guideline values for the maximum permissible start up times are to be taken into consideration when starting up squirrel-cage motors with direct switching in order to avoid thermal overloads when switching-on.

We provide the starting times on request.

### 2.4 Drive motors with free-floating belt pulley

When designing a belt drive with free-floating belt pulley, it must be ensured that:

- the shafts of the driving and driven machine are exactly parallel,
- the initial belt tension is adjustable (tensioning rails, tensioning rollers etc.),
- the maximum permissible value for the radial force acting on the drive motor shaft end is not exceeded.

Flat or V-belts are mainly used in belt drive systems. The calculation of radial force as comparison to the maximum permissible radial force of selected motor has to be done as follows:

#### 2.4.1. Calculation of the radial force on the belt pulley

$$F_r = 2 \cdot 10^7 \frac{P_n \cdot C_V}{n_n \cdot D_R} \quad \text{with:}$$

$F_r$	- Radial force [N]
$P_n$	- Rated output of drive motor [kW]
$C_V$	- Initial tension factor of belt
$n_n$	- Rated speed of drive motor [rpm]
$D_R$	- Belt pulley diameter [mm]

Approximate values for the initial tension factor  $C_V$  are given in the following table:

Type of belt	Initial tension factor $C_V$
V-belts	~2.2
Normal flat leather belts with tensioning roller	~2.7
Normal flat leather belts without tensioning roller	~4.5
Special belts	~2.1.....3.0

#### 2.4.2 Calculation of mass force

$$F_R = m_R \cdot g \quad \text{with:}$$

- $F_R$  - Mass force acting vertically downwards [N]
- $m_R$  - Weight of belt pulley [kg]
- $g$  - Gravitation ( $9.81\text{ms}^{-2}$ )

#### 2.4.3 Calculation of the actual radial force that exists

$$F_{r \text{ exist}} = \sqrt{F_r^2 + F_R^2 - 2 \cdot F_r \cdot F_R \cdot \cos(180^\circ - \gamma)}$$

with:

- $F_R$  - Mass force acting vertically downwards [N]
- $F_r$  - Radial force [N]
- $\gamma$  - Angle between  $F_R$  and  $F_r$

The radial force  $F_R$  calculated acc. to 2.4.1 is applied at the shaft end at a distance of  $x = 0.5 B_R$  from the shaft shoulder (i.e., with the half width of belt pulley) and always acts on the pulling side of belt.

Therefore selected motor is suitable for an appropriate built-on belt pulley only if calculated actual radial force according to 2.4.3 does not exceed permissible radial force for the respective type of motor.

Diagrams showing the permissible radial force for all the possible types can be provided on request. Of course, we can also design the belt drive to suit your special drive case.

#### 2.4.4 Attachment of belt pulley

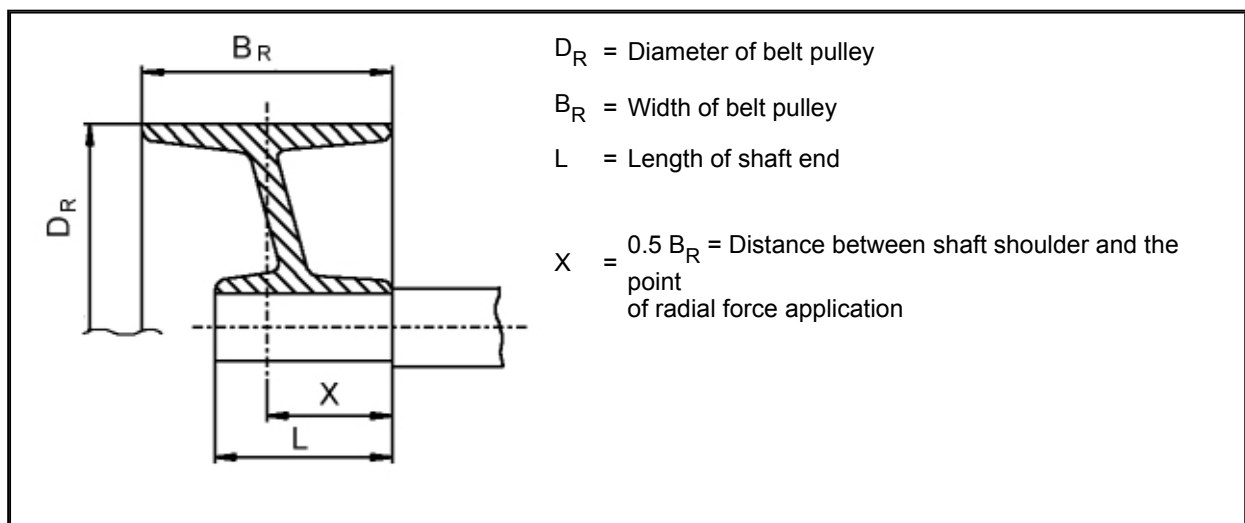

### 2.4.5 Direction and size of existing forces

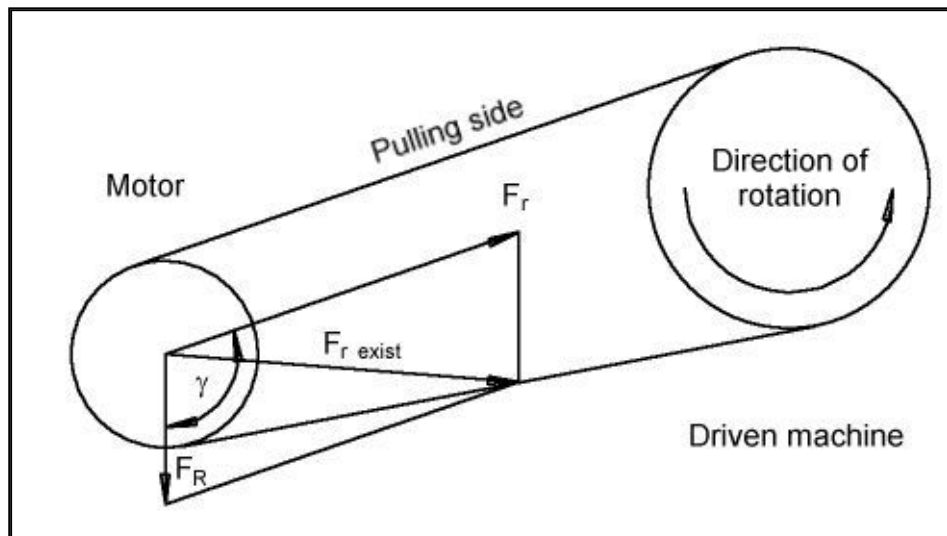

### 2.5 Enquiries / Order data

The information given in this Technical information enables the user to select a suitable motor. However, if you have specific requirements extending beyond this framework, please provide us with as precise as possible information on the special drive case.

In case of an enquiry or order please supply the following data.

1. Rated output [kW]
2. Rated speed [rpm]
3. Rated voltage [V]
4. Rated frequency [Hz]
5. Type of duty, drive clearance
6. Type of construction
7. Operation at the frequency inverter, type of inverter, speed setting
8. Ambient temperature [°C], possible installation height [metres above sea level]
9. Type of machine to be driven
10. Acceptance or production regulations
11. Type of starting (direct online, star-delta, starter, inverter)
12. External moment of inertia [kgm<sup>2</sup>], based on motor shaft
13. Torque-speed characteristic of machine to be driven
14. Number of starts, brakings, reversals with details of existing counter-torque
15. Residual voltage switchover
16. Special requirements regarding the starting current, starting torque, breakdown torque, rotor data etc.
17. Further specific features of drive motor (e.g. belt drive, inclined position, rotational direction)
18. In case of the motors with water cooling (IC 81W, IC 86W and IC 71W) please also send us the maximal temperature for the inflowing water and the water quality (fresh water, industrial water, salt water etc.)

In the case of a replacement or exchange of a VEB Elektromotorenwerk Dessau or AEM Dessau GmbH motor already in use, please also send us details of the order number or serial number.

### 2.6 Dimensions

The constructive design of the A, R, U and W series motors are shown in the dimensions drawings in the appendix to this catalogue. For the purposes of simplified illustration the dimensions of the 4- to 12-pole standard version in type B3 are shown only. Dimensioned drawings for the 2-pole design or for special designs (vertical types, V-belt drive, slip-ring rotors with brush lifting device etc.) are available on request.

All dimensions are non-binding unless confirmed by us. We reserve the right to make design changes in the interest of technical progress.

## 2.7 Symbols and conversions

Rated torque	$M_n = \frac{P_n}{\eta_n} \cdot 9560 \quad [\text{Nm}]$
Rated current	$I_n = \frac{P_n \cdot 10^5}{1,73 \cdot U_n \cdot \cos\varphi_n \cdot \eta_n} \quad [\text{A}]$
Factor of inertia	$FI = \frac{J+J_F}{J}$
Starting time	$t_A = \frac{FI \cdot J \cdot \eta_n}{9,56 \cdot (f_A \cdot M_n - M_G)}$
$P_n$	Rated output [kW]
$\eta_n$	Rated speed [rpm]
$U_n$	Rated voltage [V]
$\cos\varphi_n$	Power factor at rating
$\eta_n$	Efficiency at rating [%]
$J$	Rotor moment of inertia [ $\text{kgm}^2$ ]
$J_F$	External moment of inertia [ $\text{kgm}^2$ ], based on motor shaft
$M_G$	Mean counter-torque [Nm]
$f_A$	Starting factor for direct start



**Three-phase asynchronous motor with squirrel-cage rotor RH/RK, shaft height 355 mm, IP 55**

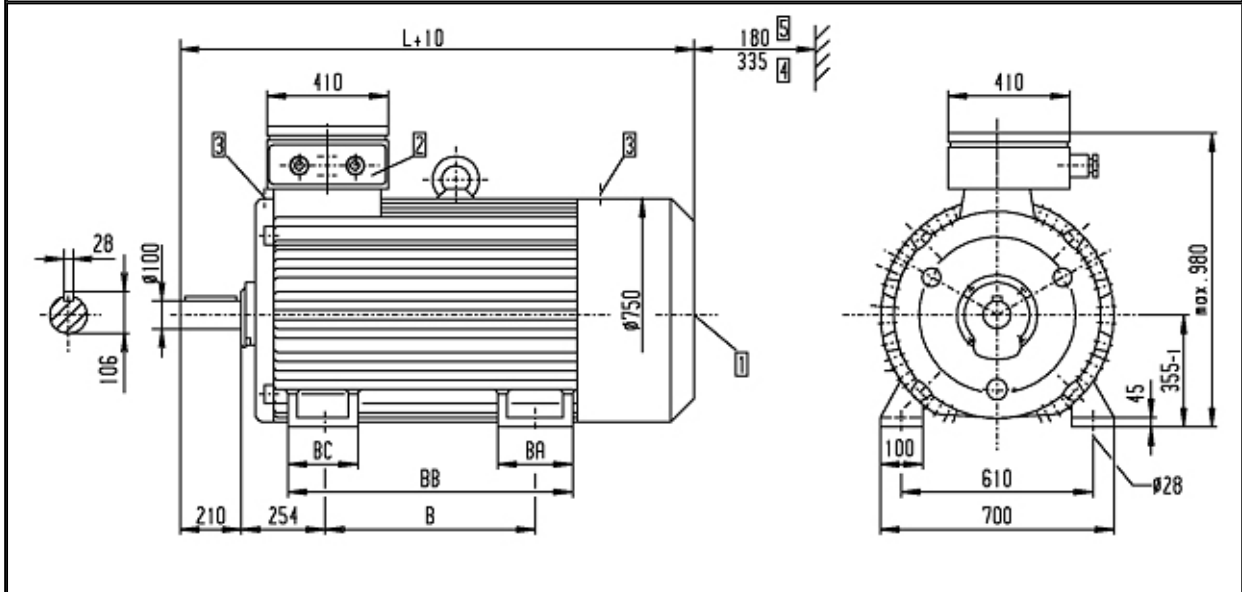

- 1 Air inlet
- 2 Terminal box rotatable by 180°
- 3 Grease nipple
- 4 Dismantling measure for fan cover
- 5 Minimum measure for air inlet

Fits:  
Shaft end m6

Type:	B	BA	BB	BC	L
RH/RK 355 SA RH/RK 355 S	500	140	640	140	1420
RH/RK 355 MA RH/RK 355 M RH/RK 355 ML	560	250	810	190	1620
RH/RK 355 L	630				

The drawing of the medium-voltage design motors differs with respect to the dimensions of the stator terminal box only. The following dimensions apply for all series:

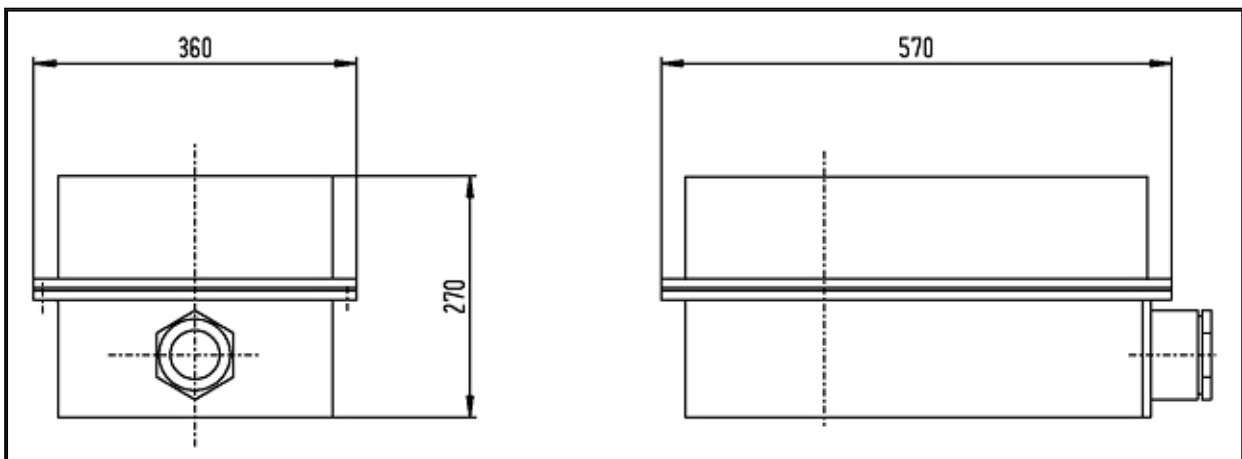



**Three-phase asynchronous motor with squirrel-cage rotor RH/RK, shaft height 400 mm, IP 55**

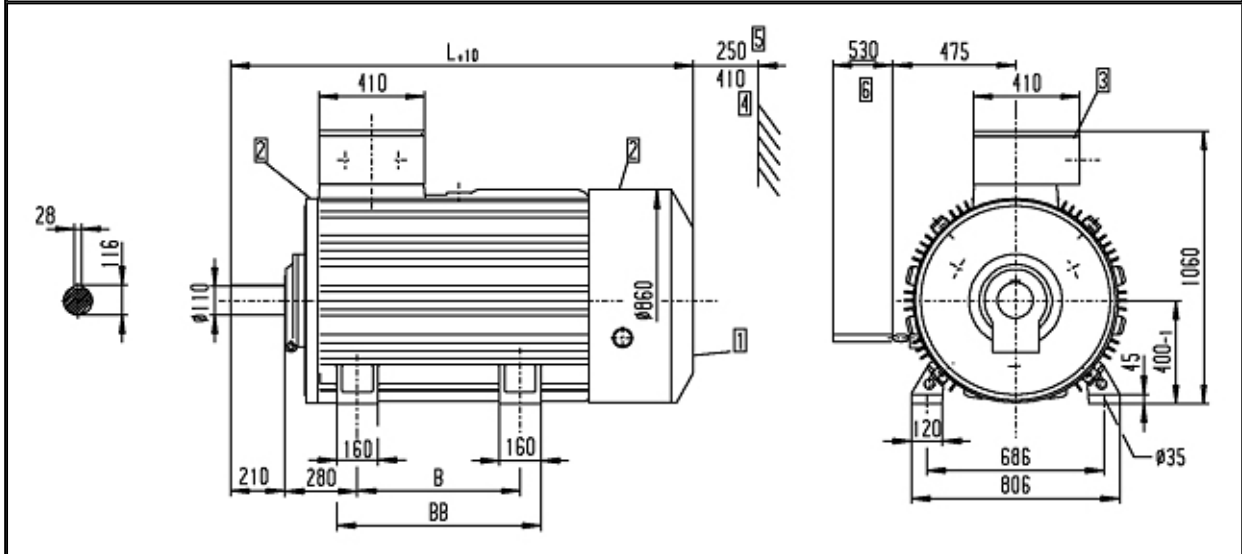

- 1 Air inlet
- 2 Grease nipple
- 3 Terminal box rotatable by 180°
- 4 Dismantling measure for fan cover
- 5 Minimum measure for air inlet
- 6 Required dismantling measure selected right or left of the motor side

Type:	B	BB	L
RH/RK 400 SA RH/RK 400 S	560	720	1680
RH/RK 400 MA RH/RK 400 M	630	790	1790
RH/RK 400 L RH/RK 400 LL	710	870	1950

Fits:  
Shaft end m6

The drawing of the medium-voltage design motors differs with respect to the dimensions of the stator terminal box only. The following dimensions apply for all series:

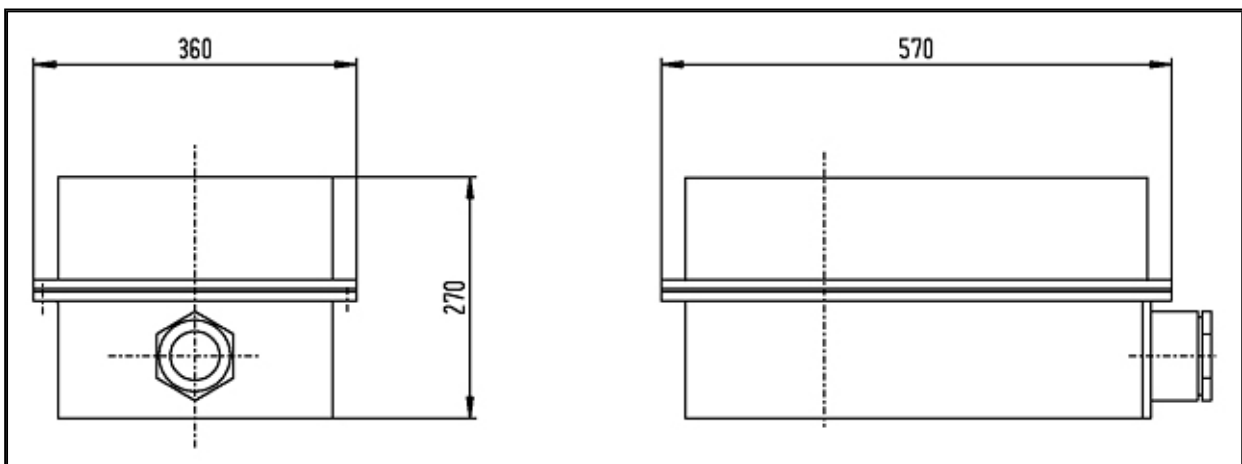



**Three-phase asynchronous motor with squirrel-cage rotor 2RH/2RK, shaft height 400 mm, IP 55**

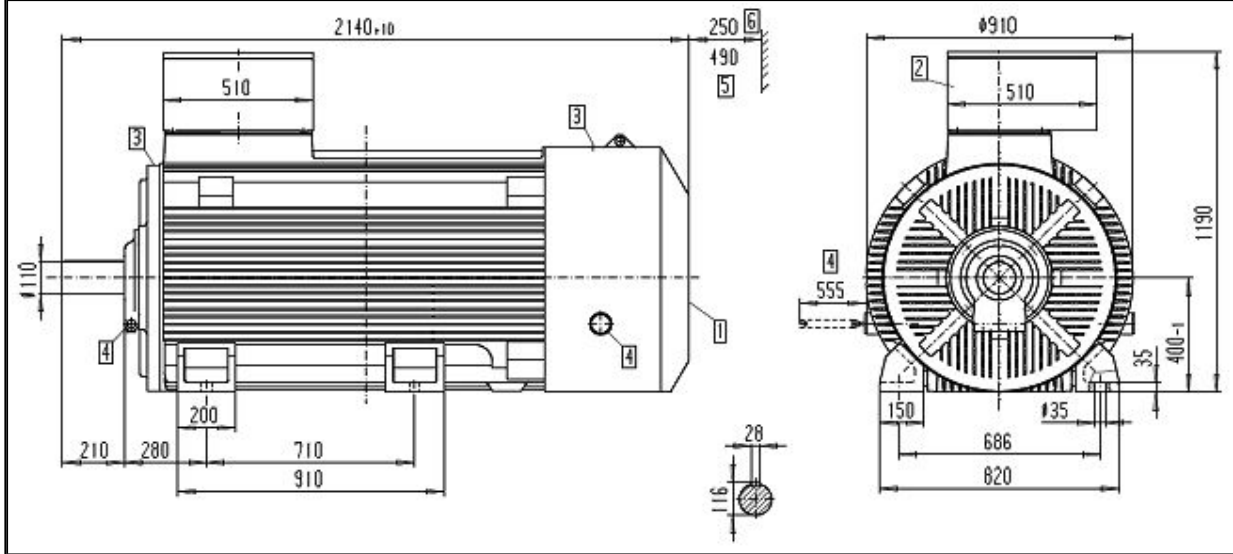

- 1 Air inlet
- 2 Terminal box rotatable by 180°
- 3 Grease nipple
- 4 Waste grease taking
- 5 Dismantling measure for fan cover
- 6 Minimum measure for air inlet

Fits:

Shaft end m6

Number and size of cable entries acc. to arrangement.  
For direct coupling only!

The drawing of the medium-voltage design motors differs with respect to the dimensions of the stator terminal box only. The following dimensions apply for all series:

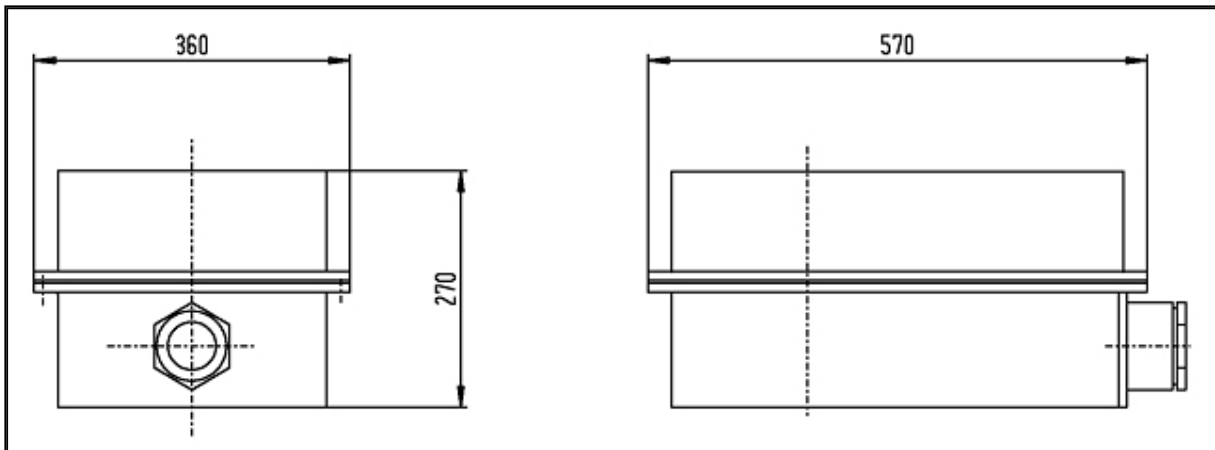



**Three-phase asynchronous motor with squirrel-cage rotor RH/RK, shaft height 450 mm, IP 55**

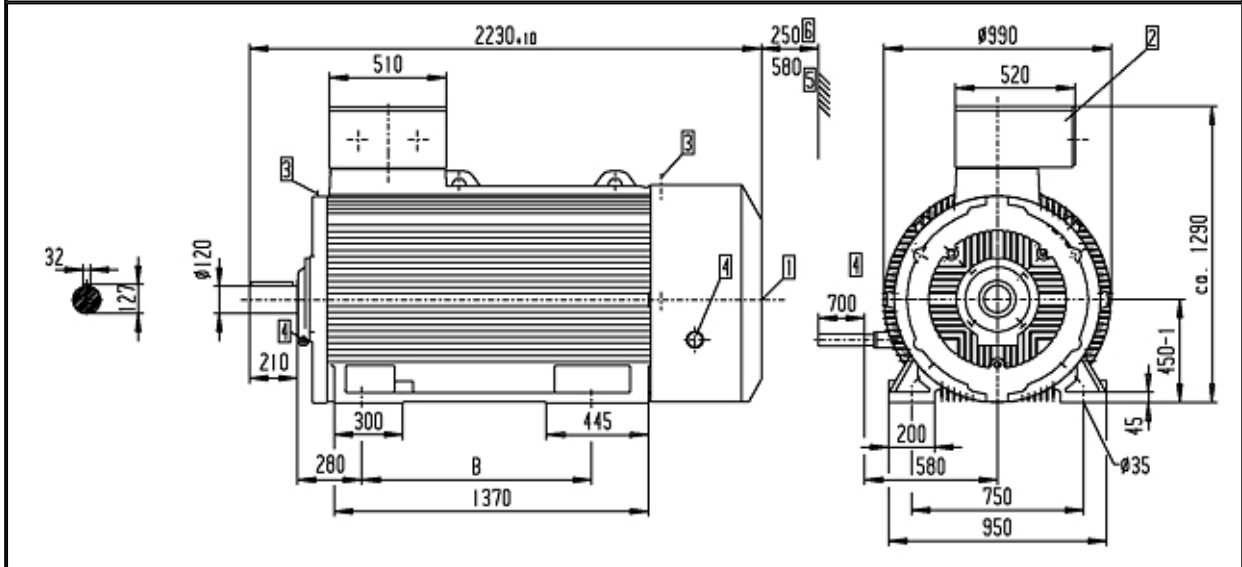

- 1 Air inlet
- 2 Terminal box rotatable by 180°
- 3 Grease nipple
- 4 Waste grease taking
- 5 Dismantling measure for fan cover
- 6 Minimum measure for air inlet

Type:	B
RH/RK 450 S	900
RH/RK 450 M	1000
RH/RK 450 L	1120

Fits:

Shaft end m6

The drawing of the medium-voltage design motors differs with respect to the dimensions of the stator terminal box only. The following dimensions apply for all series:

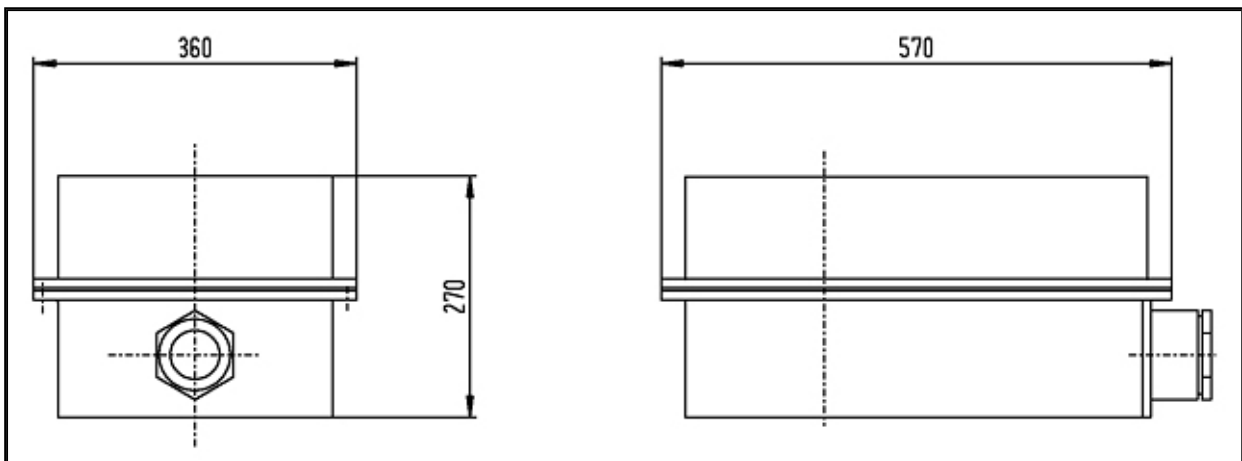



**Three-phase asynchronous motor with squirrel-cage rotor RH/RK, shaft height 500 mm, IP 55**

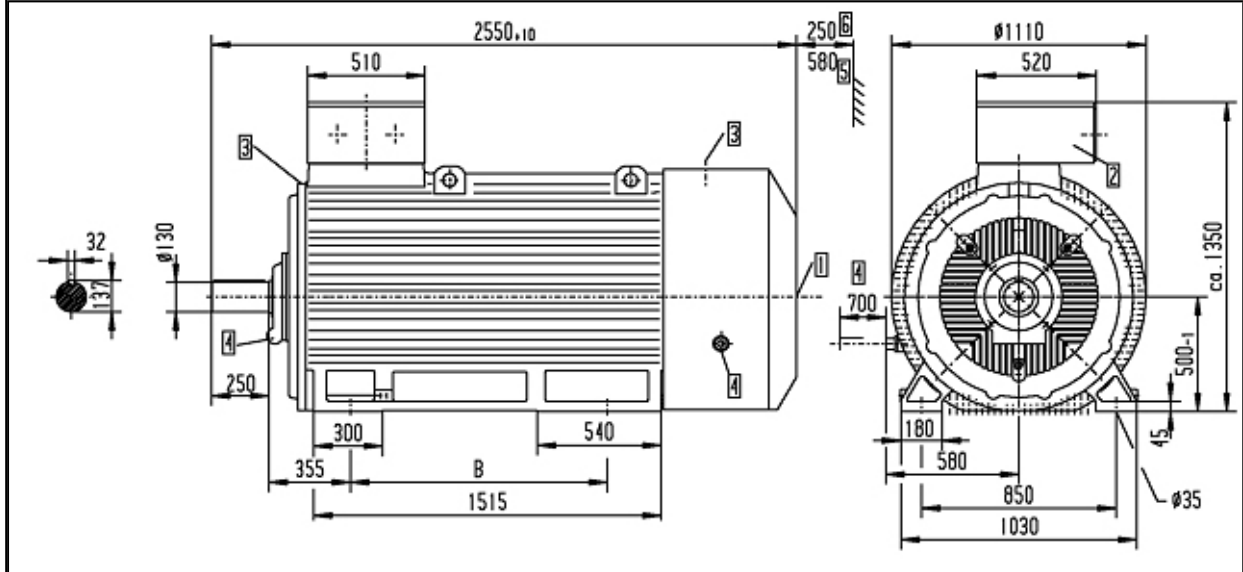

- 1 Air inlet
- 2 Terminal box rotatable by 180°
- 3 Grease nipple
- 4 Waste grease taking
- 5 Dismantling measure for fan cover
- 6 Minimum measure for air inlet

Type:	B
RH/RK 500 MA	1120
RH/RK 500 M	1120
RH/RK 500 L	1250

Fits:  
Shaft end m6

The drawing of the medium-voltage design motors differs with respect to the dimensions of the stator terminal box only. The following dimensions apply for all series:

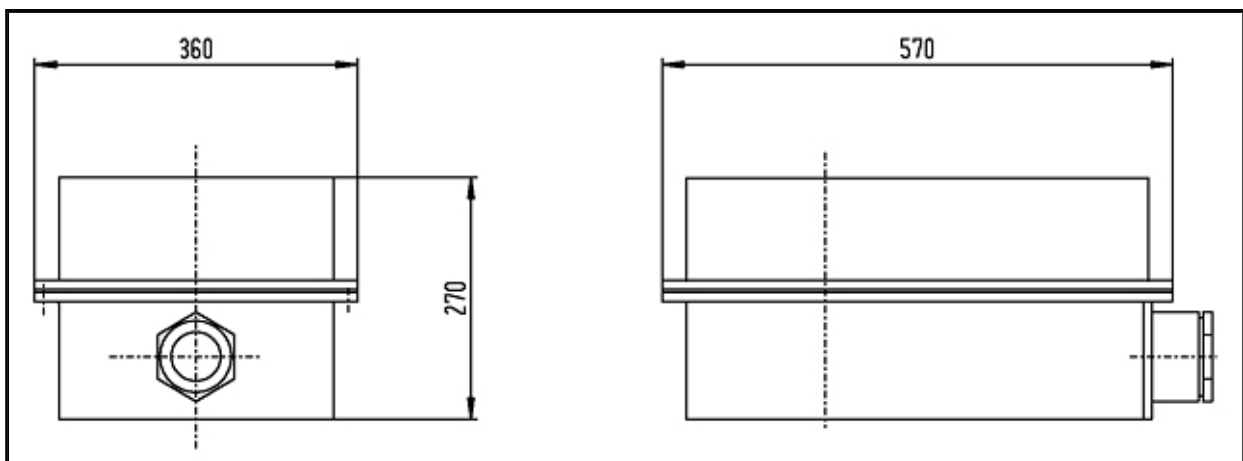





**Three-phase asynchronous motor with slip-ring rotor RS, shaft height 355 mm, IP 55**

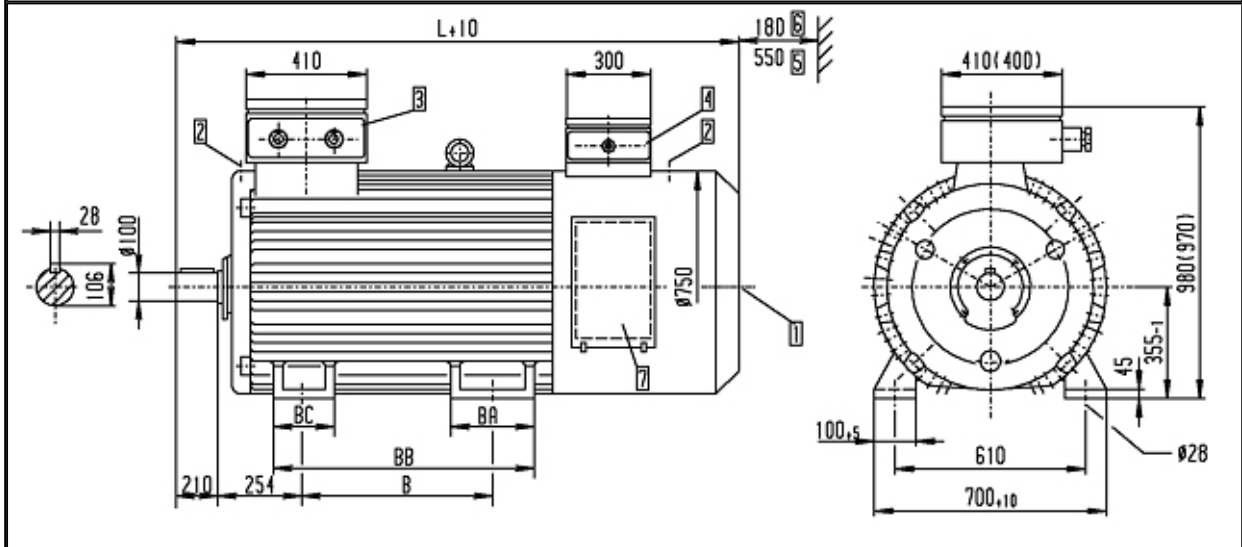

- 1 Air inlet
- 2 Grease nipple
- 3 Stator connection: terminal box rotatable by 180°
- 4 Rotor connection: terminal box rotatable by 180°
- 5 Dismantling measure for fan cover
- 6 Minimum measure for air inlet
- 7 Opening for slip-ring and filter behind the cover

Type:	B	BA	BB	BC	L
RS 355 SA RS 355 S	500	140	640	140	1620
RS 355 MA RS 355 M	560	250	810	190	1830

Fits:

Shaft end m6

The drawing of the medium-voltage design motors differs with respect to the dimensions of the stator terminal box only. The following dimensions apply for all series:

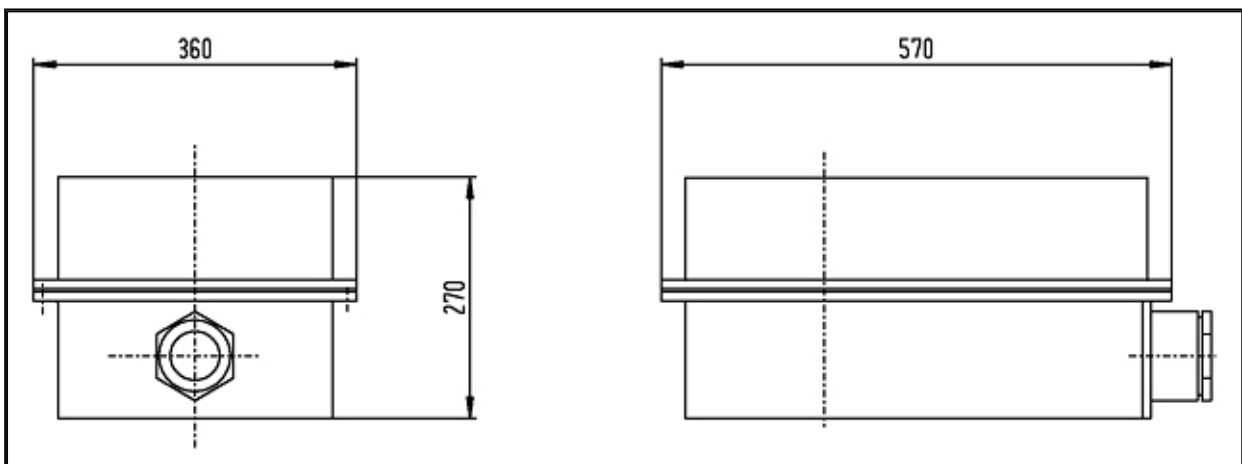

**3.1.7 Three-phase asynchronous motor with slip-ring rotor, shaft height 400 mm, degree of protection IP 55, cooling method IC 411**

Type	Frame size		Rated voltage [V]	Rated output [kW]					
	Shaft height [mm]	Length		Number of poles					
					4	6	8	10	12
RS	400	SA	400					160	132
		S		400	315	250	200	160	
		MA							
		M		500	400	315	250	200	
		ML							
RSB		L	630	500	400	315	250		
RSR		SA	6000		110				
		S		160	132	110	90	75	
		MA		200	160	132			
		M		250	200	160	110	90	
	ML								
	L	315	250	200	132	110			

**Type:**

**RS... Slip-ring rotor**

**RSB... Version with brush lifting device (manual / motorized)**

**RSR... 4- to 12-pole: Suitable for belt drive on request only**

Rated voltage: 220 V ( $\Delta$ ) to 6600 V (Y)

Rated frequency: 50 Hz

Ambient temperature: 40 °C

Height above sea level: max. 1000 m

**Three-phase asynchronous motor with slip-ring rotor RS, shaft height 400 mm, IP 55**

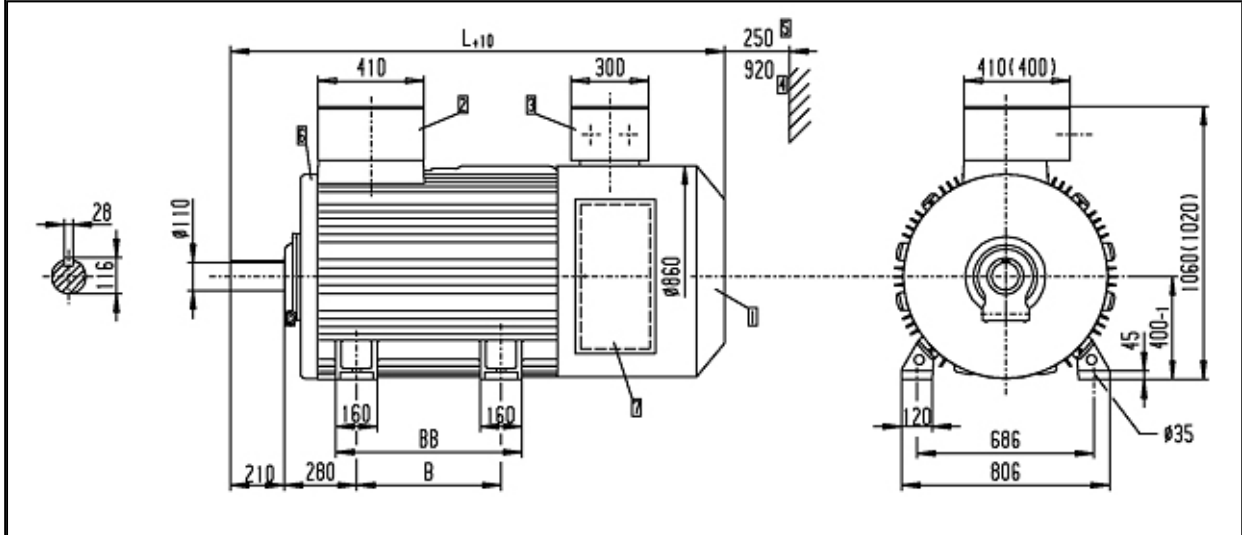

- 1 Air inlet
- 2 Stator connection: terminal box rotatable by 180°
- 3 Rotor connection: terminal box rotatable by 180°
- 4 Dismantling measure for fan cover
- 5 Minimum measure for air inlet
- 6 Grease nipple
- 7 Opening for slip-ring, filter and waste grease taking behind the cover

Type:	B	BB	L
RS 400 SA	560	720	1915
RS 400 S	560	720	1915
RS 400 MA	630	790	2025
RS 400 M	630	790	2025
RS 400 L	710	870	2190

Fits:  
Shaft end m6

The drawing of the medium-voltage design motors differs with respect to the dimensions of the stator terminal box only. The following dimensions apply for all series:

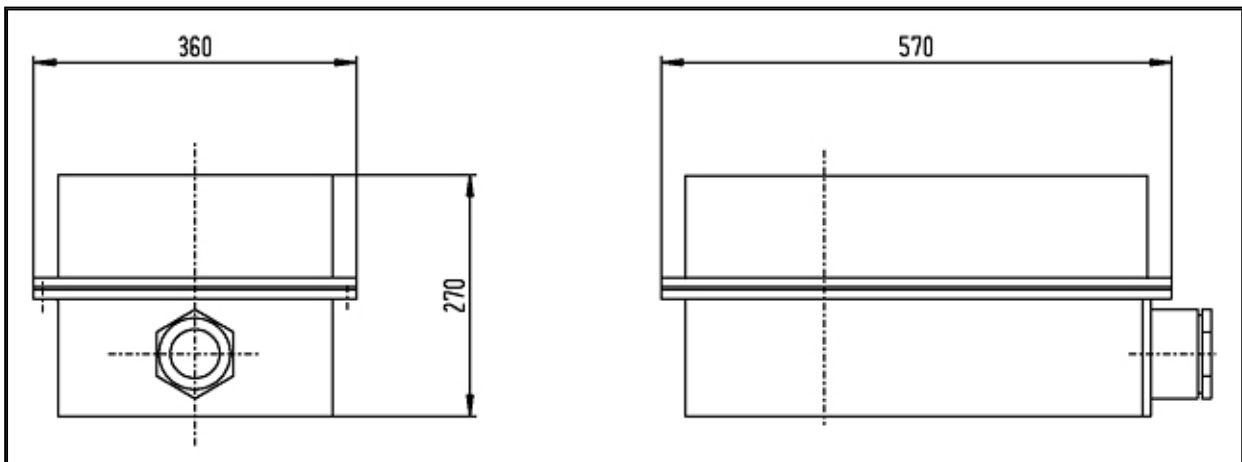

**3.1.8 Three-phase asynchronous motor with slip-ring rotor, shaft height 450 mm, degree of protection IP 55, cooling method IC 411**

Type	Frame size		Rated voltage [V]	Rated output [kW]					
	Shaft height [mm]	Length		Number of poles					
				4	6	8	10	12	
RS	450	SA	400						
		S							
		MA							
		M		800	630				
		ML							
RSB		L		800	500	400	315		
RSR		SA	6000						
		S		400	315	250	160	132	
		MA							
		M		500	400	315	200	160	
	ML								
	L		630	450	355	250	200		

**Type:**

**RS... Slip-ring rotor**

**RSB... Version with brush lifting device (manual / motorized)**

**RSR... 4- to 12-pole: Suitable for belt drive on request only**

Rated voltage: 220 V ( $\Delta$ ) to 6600 V (Y)

Rated frequency: 50 Hz

Ambient temperature: 40 °C

Height above sea level: max. 1000 m

**Three-phase asynchronous motor with slip-ring rotor RS, shaft height 450 mm, IP 55**

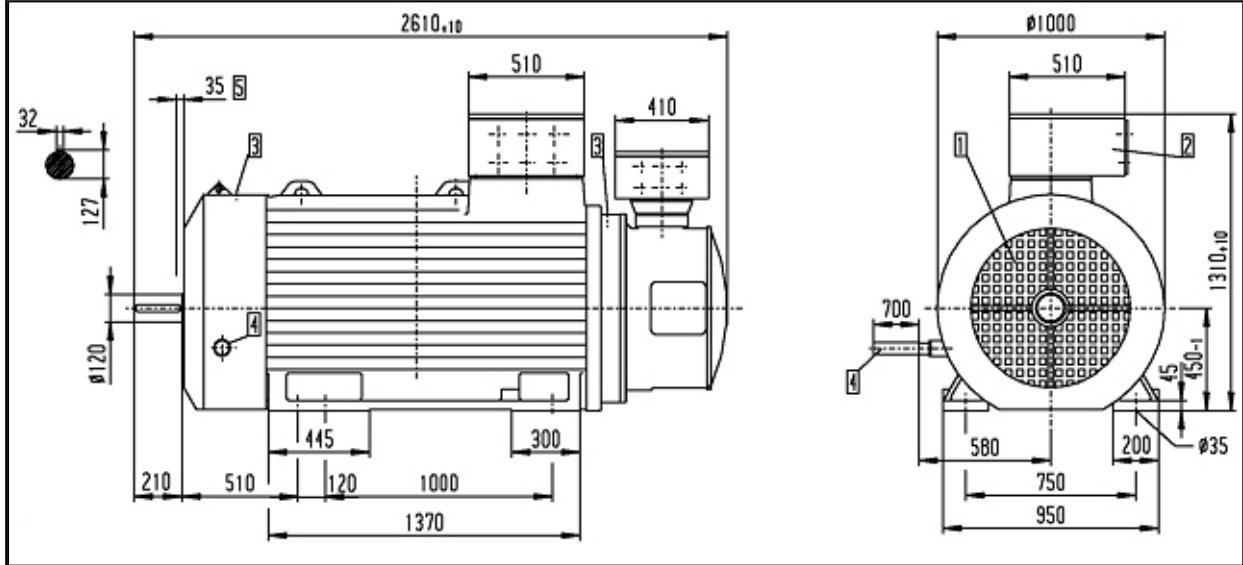

- 1 Air inlet
- 2 Terminal box rotatable by 180°
- 3 Grease nipple
- 4 Waste grease taking
- 5 Minimum measure for air inlet

Fits:

Shaft end m6

The drawing of the medium-voltage design motors differs with respect to the dimensions of the stator terminal box only. The following dimensions apply for all series:

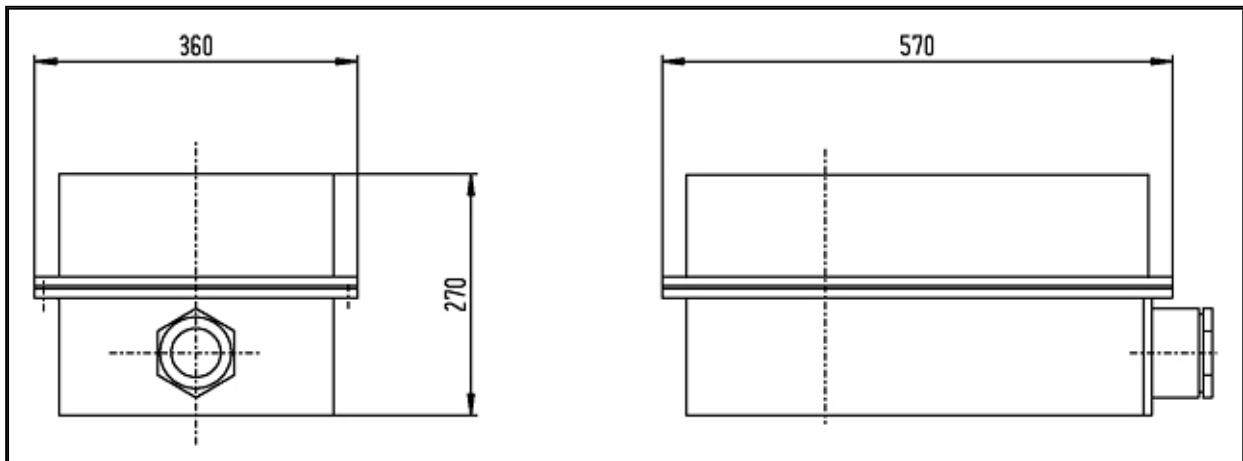

**3.1.9 Three-phase asynchronous motor with slip-ring rotor, shaft height 500 mm, degree of protection IP 55, cooling method IC 411**

Type	Frame size		Rated voltage [V]	Rated output [kW]					
	Shaft height [mm]	Length		Number of poles					
					4	6	8	10	12
RS	500	SA	400						
		S							
		MA							
		M							
		ML							
RSB		L		1000	900	630	500	400	
RSR		SA	6000						
		S							
		MA				500	400		
		M			800	630	500	315	250
	ML								
	L		1000	710	560	400	315		

**Type:**

**RS... Slip-ring rotor**

**RSB... Version with brush lifting device (manual / motorized)**

**RSR... 4- to 12-pole: Suitable for belt drive on request only**

Rated voltage: 220 V ( $\Delta$ ) to 6600 V (Y)

Rated frequency: 50 Hz

Ambient temperature: 40 °C

Height above sea level: max. 1000 m

**Three-phase asynchronous motor with slip-ring rotor RS, shaft height 500 mm, IP 55**

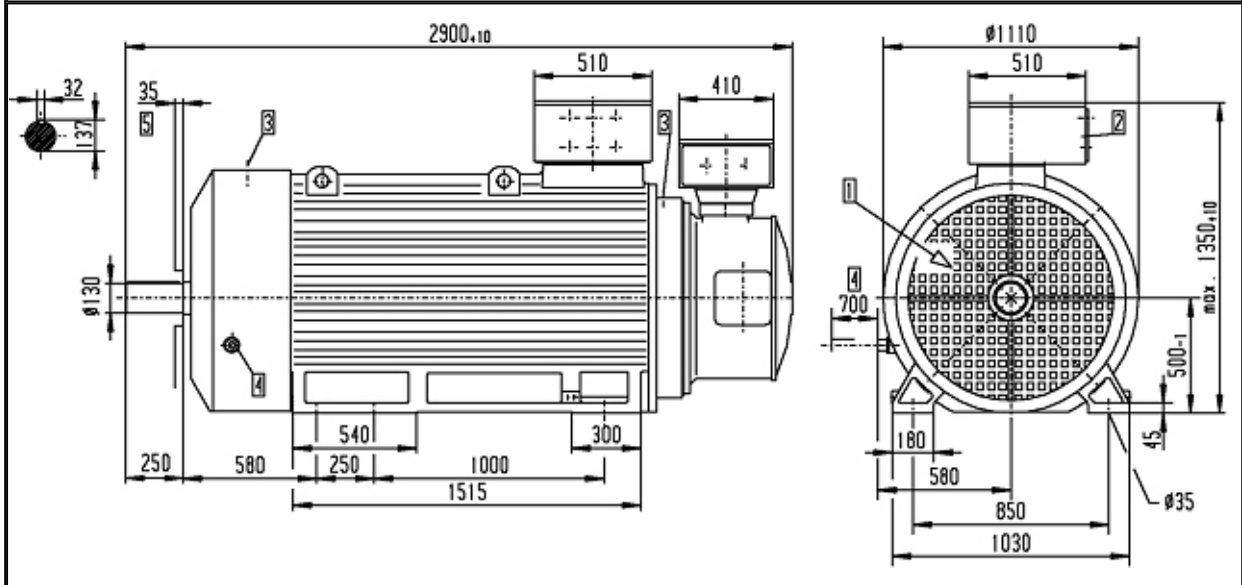

- 1 Air inlet
- 2 Terminal box rotatable by 180°
- 3 Grease nipple
- 4 Waste grease taking
- 5 Minimum measure for air inlet

fits:  
shaft end m6

The drawing of the medium-voltage design motors differs with respect to the dimensions of the stator terminal box only. The following dimensions apply for all series:

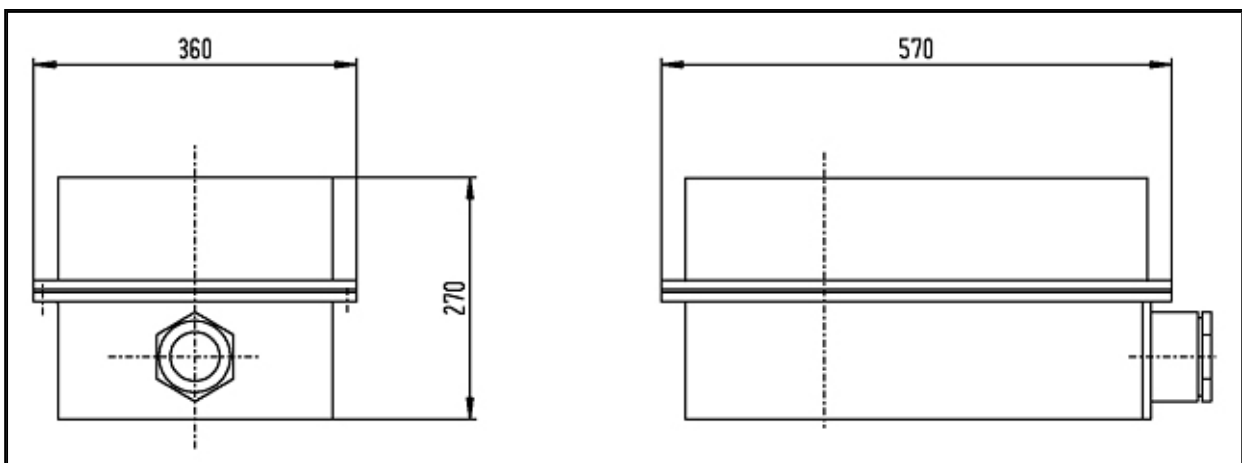

**3.1.10 Three-phase asynchronous motor with slip-ring rotor for crane duty, shaft height 355 mm, degree of protection IP 55, cooling method IC 411**

Type	Frame size		Duty type S3 [%]	Rated voltage [V]	Rated output [kW]					
	Shaft height [mm]	Length			Number of poles					
					2	4	6	8	10	12
RSK	355	SA	60	400			132	110		
		S					160	132	90	75
		MA					200	160	110	90
		M					250	200	132	110
		SA	40				160	132		
		S					200	160	110	90
		MA					250	200	132	110
		M					315	250	160	132
		SA	20				200	160		
		S					250	200	132	110
		MA					315	250	160	132
		M					400	315	200	160

**Type:**

**RSK... Crane duty**

Rated voltage: 220 V ( $\Delta$ ) to 1000 V ( $\Delta / Y$ )

Rated frequency: 50 Hz

Ambient temperature: 40 °C

Height above sea level: max. 1000 m

**3.1.11 Three-phase asynchronous motor with slip-ring rotor for crane duty, shaft height 400 mm, degree of protection IP 55, cooling method IC 411**

Type	Frame size		Duty type S3 [%]	Rated voltage [V]	Rated output [kW]						
	Shaft height [mm]	Length			Number of poles						
					6	8	10	12			
RSK	400	SA	60	400			230				
		S					315	250	160	132	
		M					400	315	200	160	
		L					500	400	250	200	
		SA	40					280			
		S					400	315	200	160	
		M					500	400	250	200	
		L					630	500	315	250	
		SA	20					350			
		S					500	400	250	200	
		MA					630	500	315	250	
		L					800	630	400	315	

**Type:**

**RSK... Crane duty**

Rated voltage: 220 V (Δ) to 1000 V (Δ / Y)

Rated frequency: 50 Hz

Ambient temperature: 40 °C

Height above sea level: max. 1000 m

**3.1.12 Three-phase asynchronous motor with slip-ring rotor for crane duty, shaft height 450 mm, degree of protection IP 55, cooling method IC 411**

Type	Frame size		Duty type S3 [%]	Rated voltage [V]	Rated output [kW]				
	Shaft height [mm]	Length			Number of poles				
					6	8	10	12	
RSK	450	SA	60	400					
		S							
		M					315	250	
		L			630	500	400	315	
		SA	40						
		S							
		M					400	315	
		L			800	630	500	400	
		SA	20						
		S							
		M					500	400	
		L			1000	800	630	500	

**Type:**

**RSK... Crane duty**

Rated voltage: 220 V (Δ) to 1000 V (Δ / Y)

Rated frequency: 50 Hz

Ambient temperature: 40 °C

Height above sea level: max. 1000 m

**3.1.13 Three-phase asynchronous motor with slip-ring rotor for crane duty, shaft height 500 mm, degree of protection IP 55, cooling method IC 411**

Type	Frame size		Duty type S3 [%]	Rated voltage [V]	Rated output [kW]				
	Shaft height [mm]	Length			Number of poles				
					6	8	10	12	
RSK	500	SA	60	400					
		S							
		M			800				
		L			900	630	500	400	
		SA	40						
		S							
		M			1000				
		L			1120	800	630	500	
		SA	20						
		S							
		M			1250				
		L			1400	1000	800	630	

**Type:**

**RSK... Crane duty**

Rated voltage: 220 V ( $\Delta$ ) to 1000 V ( $\Delta$  / Y)

Rated frequency: 50 Hz

Ambient temperature: 40°C

Height above sea level: max. 1000 m

### 3.2 Series A (open-circuit ventilated)

#### 3.2.1 Three-phase asynchronous motor with squirrel-cage rotor, shaft height 315 mm, degree of protection IP 23, cooling method IC 01

Type	Frame size		Rated voltage [V]	Rated output [kW]					
	Shaft height [mm]	Length		Number of poles					
				2	4	6	8	10	12
AH	315	SA	400						
		S		200	160	132	90	75	40
AK		MA		250					
		MB		315	200	160	110	90	55
AHR		M		400	250	200	132	110	75
AKR		ML		500	315	250	160	132	90
		L			400	315	200	160	110
		LL			500	400	250		

Type:

**AH... Deep-bar rotor**

**AK... Double-cage rotor**

**AHR/AKR... 4- to 12-pole: Suitable for belt drive on request only**

Rated voltage: 220 V ( $\Delta$ ) to 1000 V ( $\Delta/Y$ )

Rated frequency: 50 Hz

Ambient temperature: 40 °C

Height above sea level: max. 1000 m

**Three-phase asynchronous motor with squirrel-cage rotor AH/AK, shaft height 315 mm, IP 23**

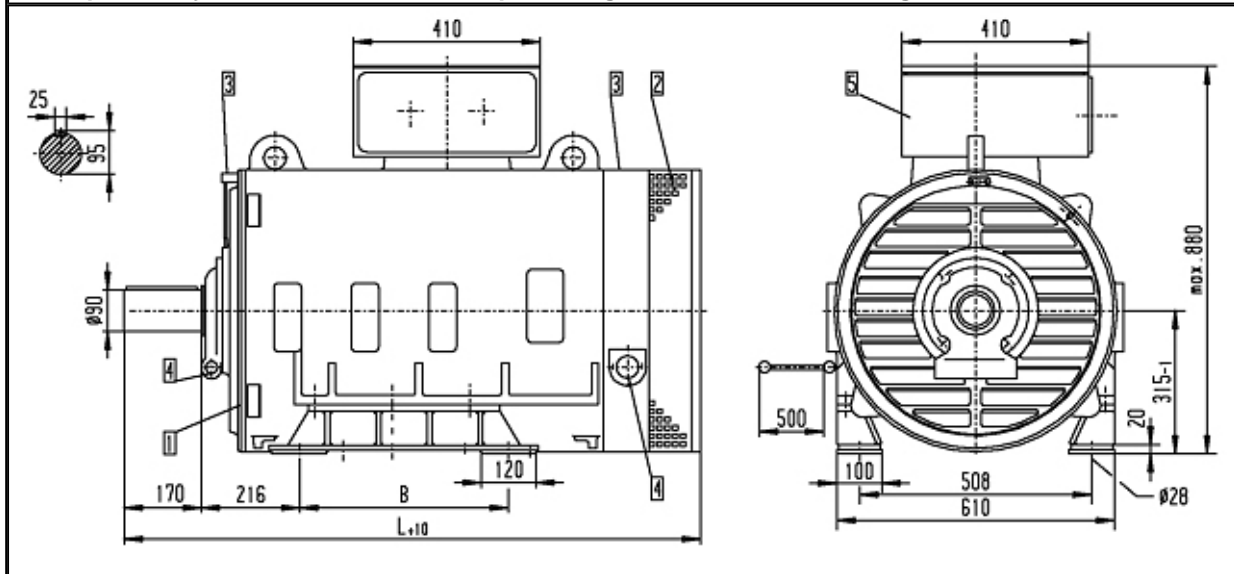

- 1 Air inlet
- 2 Air outlet
- 3 Grease nipple
- 4 Waste grease taking
- 5 Terminal box rotatable by 180°

Fits:

Shaft end m6

Type:	B	L
AH/AK 315 S	406	1180
AH/AK 315 MA	457	
AH/AK 315 MB		
AH/AK 315 M	508	1290
AH/AK 315 ML		1405
AH/AK 315 L	on request	
AH/AK 315 LL		

**3.2.2 Three-phase asynchronous motor with squirrel-cage rotor, shaft height 355 mm, degree of protection IP 23, cooling method IC 01**

Type	Frame size		Rated voltage [V]	Rated output [kW]					
	Shaft height [mm]	Length		Number of poles					
				2 <sup>1)</sup>	4	6	8	10	12
AH	355	SA	400						
		S							132
		MA							
		M		630	630	500	315	200	160
		ML							
AK		L	710	710	560	355	225	180	
AHR		SA	6000						
AKR		S		160	160	160			
		MA		200	200	200	132		
		M		250	250	250	160	110	
	ML	315		315					
	L	400	400	315	200	132	90		

<sup>1)</sup> available as AH only

**Type:**

**AH... Deep-bar rotor**

**AK... Double-cage rotor**

**AHR/AKR... 4- to 12-pole: Suitable for belt drive on request only**

Rated voltage: 220 V (Δ) to 6600 V (Y)  
 Rated frequency: 50 Hz  
 Ambient temperature: 40 °C  
 Height above sea level: max. 1000 m

**Three-phase asynchronous motor with squirrel-cage rotor AH/AK, shaft height 355 mm, IP 23**

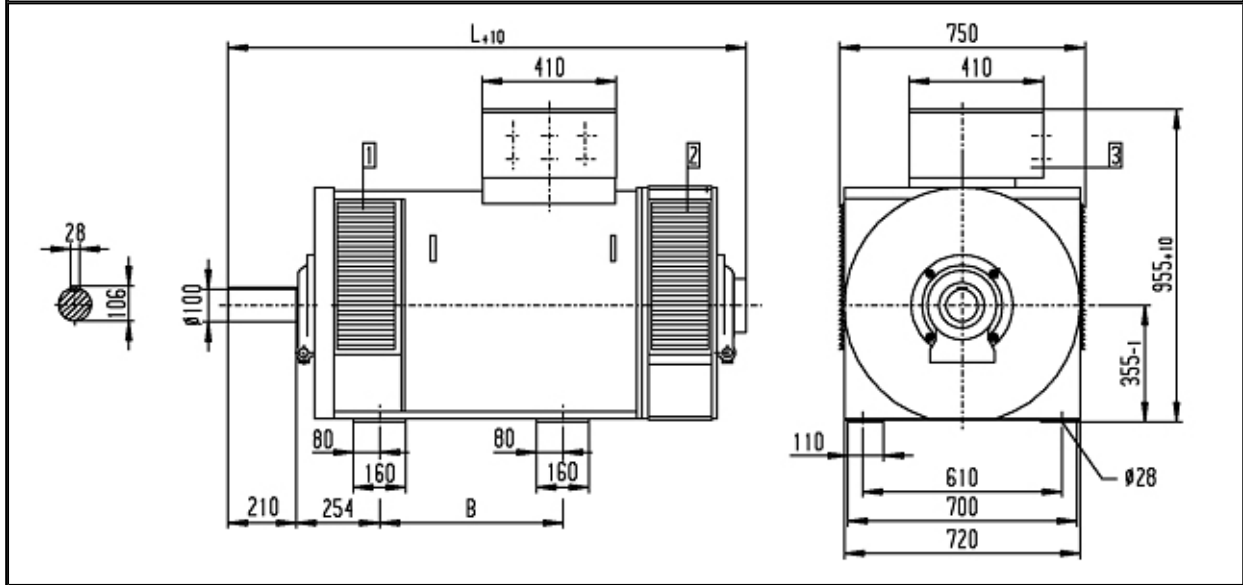

- 1 Air inlet
- 2 Air out
- 3 Terminal box rotatable by 180°

Fits:  
Shaft end m6

Type:	B	L
AH/AK 355 S	on request	on request
AH/AK 355 MA	560	
AH/AK 355 M		
AH/AK 355 ML		
AH/AK 355 L	630	

The drawing of the medium-voltage design motors differs with respect to the dimensions of the stator terminal box only. The following dimensions apply for all series:

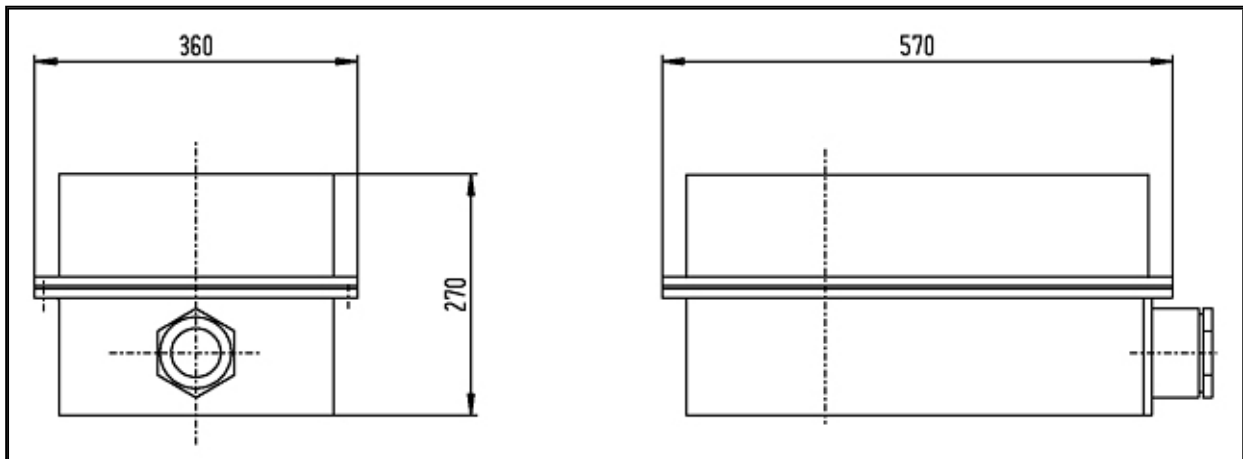

**3.2.3 Three-phase asynchronous motor with squirrel-cage rotor, shaft height 400 mm, degree of protection IP 23, cooling method IC 01**

Type	Frame size		Rated voltage [V]	Rated output [kW]						
	Shaft height [mm]	Length		Number of poles						
				2 <sup>1)</sup>	4	6	8	10	12	
AH AK	400	S	400		800	630	400	250	200	
		MA								
		M		800	1000	800	500	315	250	
		ML								
		L		1000	1250	1000	630	400	315	
AHR AKR		400	SA	6000						
			S			500				110
			MA							
			M		500	630	400	250	160	132
			ML							
AKR	400		L	6000	630	800	500	315	200	160
			LL							

<sup>1)</sup> available as AH only

**Type:**

**AH... Deep-bar rotor**

**AK... Double-cage rotor**

**AHR/AKR... 4- to 12-pole: Suitable for belt drive on request only**

Rated voltage: 220 V (Δ) to 6600 V (Y)  
 Rated frequency: 50 Hz  
 Ambient temperature: 40 °C  
 Height above sea level: max. 1000 m

**Three-phase asynchronous motor with squirrel-cage rotor AH/AK, shaft height 400 mm, IP 23**

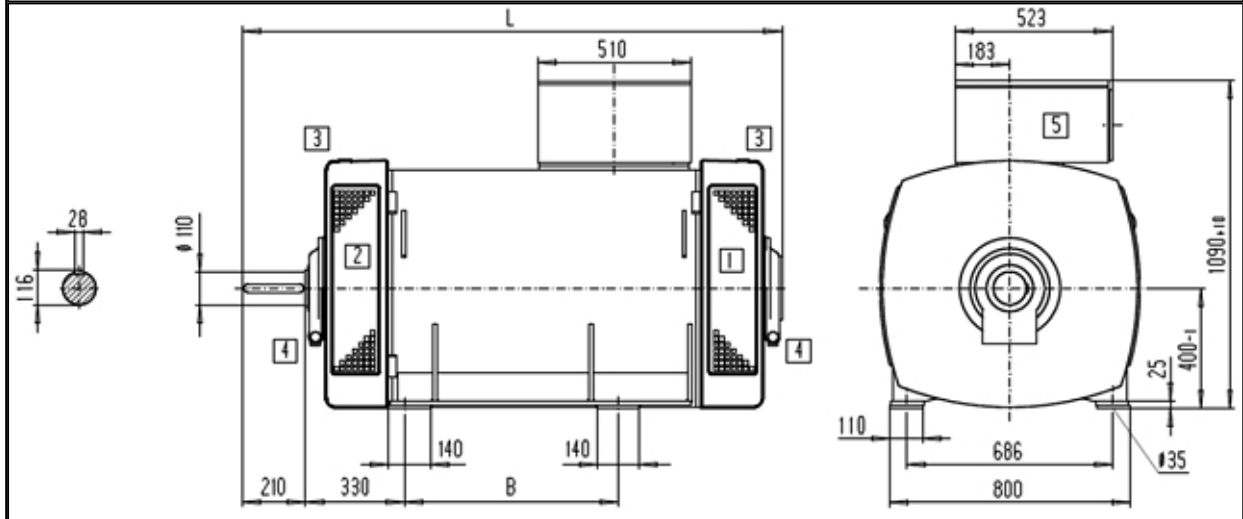

- 1 Air inlet
- 2 Air out
- 3 Grease nipple
- 4 Waste grease taking
- 5 Terminal box rotatable by 180°

Type:	B	L
AH/AK 400 S	560	on request
AH/AK 400 M	630	
AH/AK 400 L	710	

Fits:  
Shaft end m6

The drawing of the medium-voltage design motors differs with respect to the dimensions of the stator terminal box only. The following dimensions apply for all series:

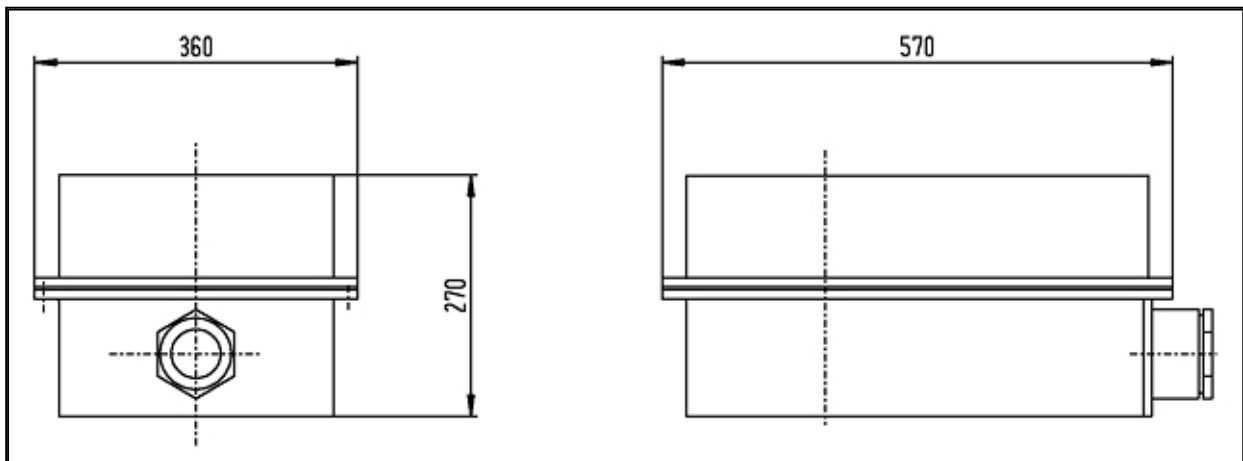



**Three-phase asynchronous motor with squirrel-cage rotor AH/AK, shaft height 450 mm, IP 23**

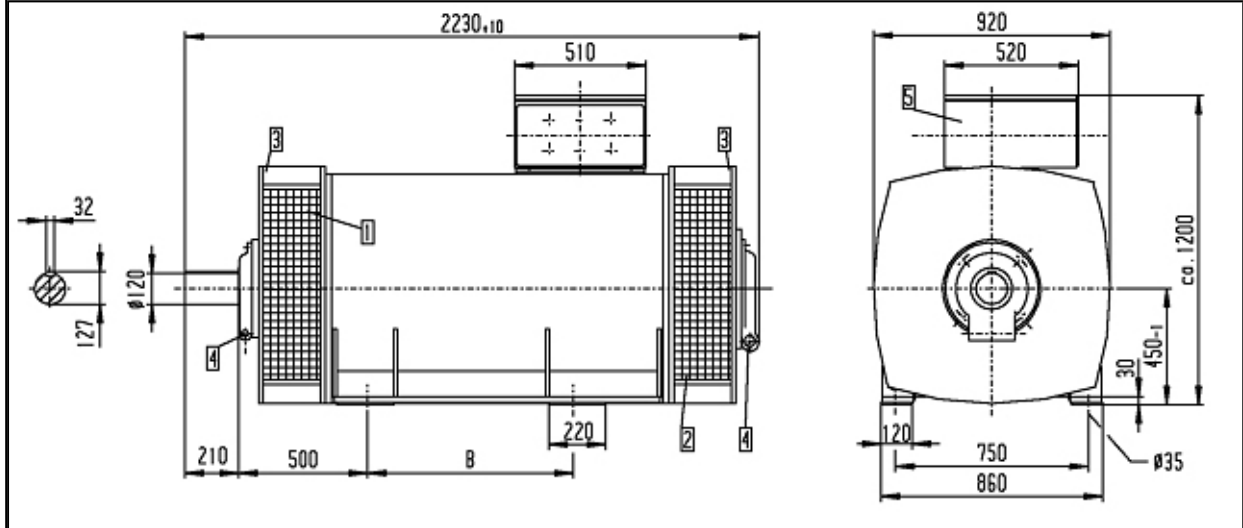

- 1 Air inlet
- 2 Air outlet
- 3 Grease nipple
- 4 Waste grease taking
- 5 Terminal box rotatable by 180°

Type:	B
AH/AK 450 S	630
AH/AK 450 MA	800
AH/AK 450 M	
AH/AK 450 L	

Fits:

Shaft end m6

The drawing of the medium-voltage design motors differs with respect to the dimensions of the stator terminal box only. The following dimensions apply for all series:

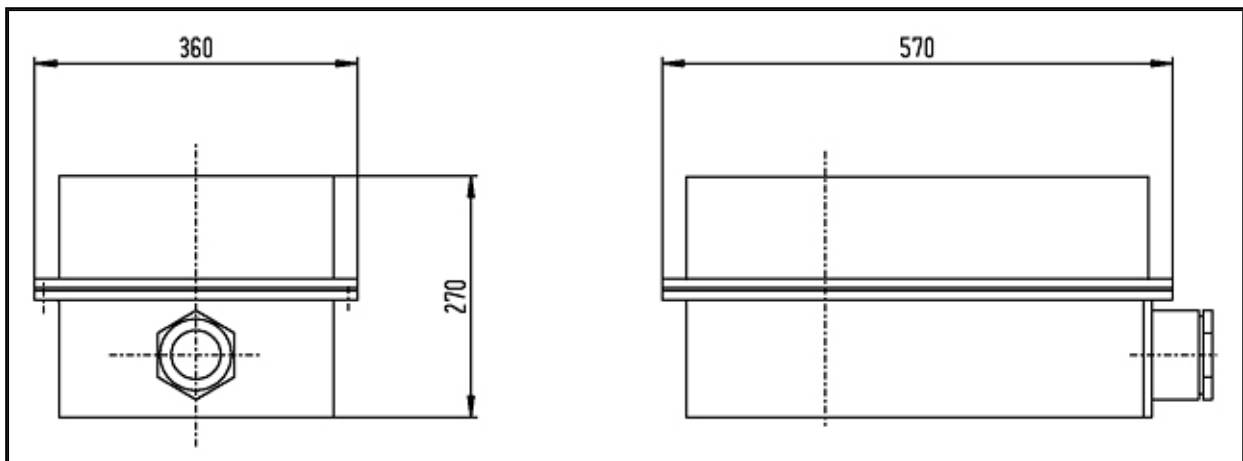



**Three-phase asynchronous motor with squirrel-cage rotor AH/AK, shaft height 500 mm, IP 23**

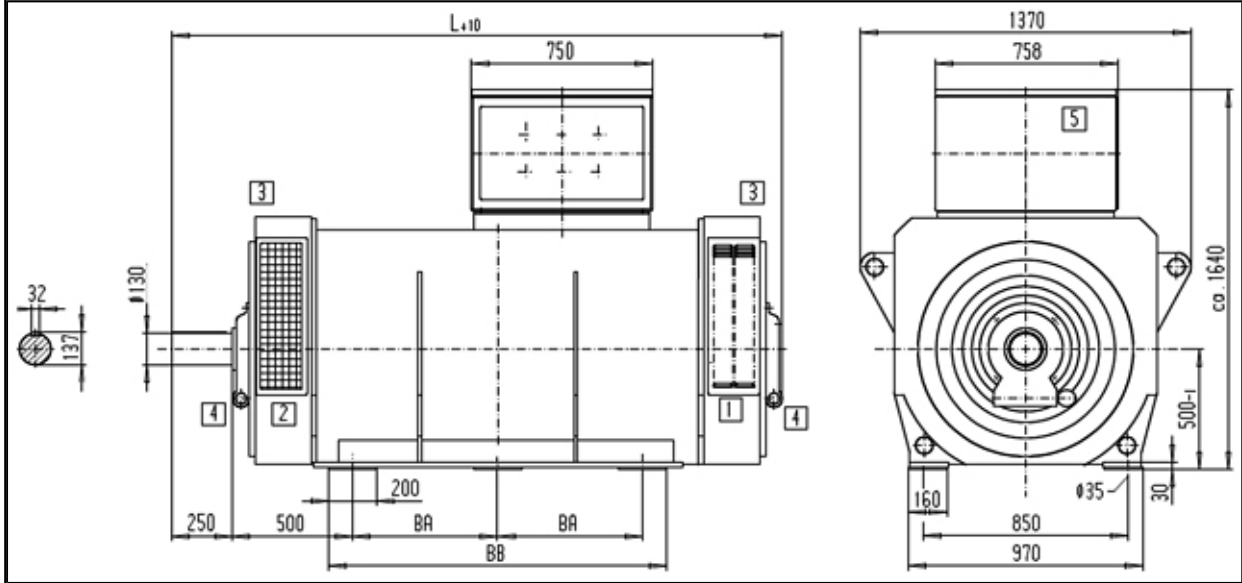

- 1 Air inlet
- 2 Air outlet
- 3 Grease nipple
- 4 Waste grease taking
- 5 Terminal box rotatable by 180°

Type:	BA	BB	L
AH/AK 500 MA	500	1200	on request
AH/AK 500 M			
AH/AK 500 L	600	1400	
AH/AK 500 LL			

Fits:  
Shaft end m6

The drawing of the medium-voltage design motors differs with respect to the dimensions of the stator terminal box only. The following dimensions apply for all series:

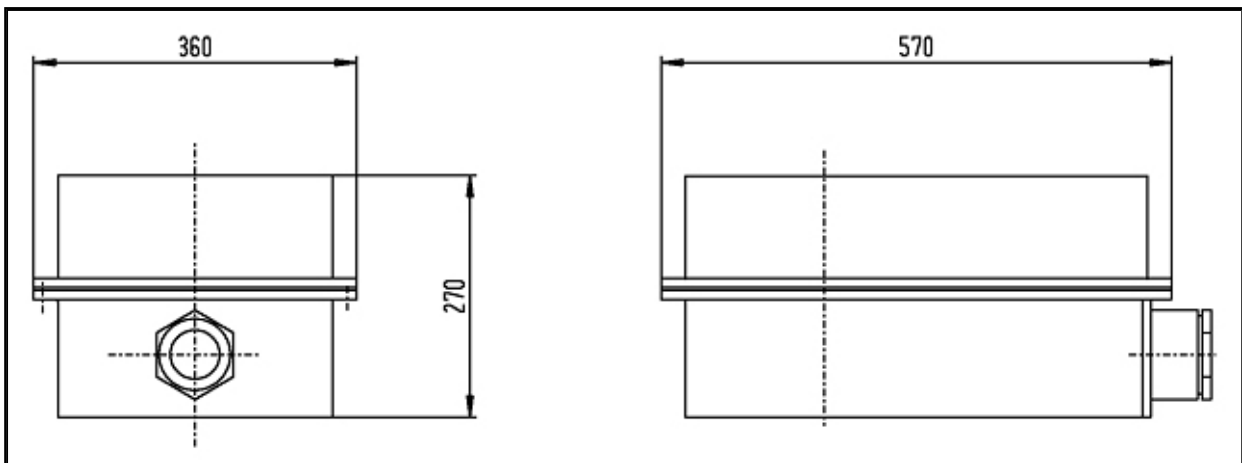



**3.2.7 Three-phase asynchronous motor with slip-ring rotor, shaft height 315 mm, degree of protection IP 23, cooling method IC 01**

Type	Frame size		Rated voltage [V]	Rated output [kW]				
	Shaft height [mm]	Length		Number of poles				
				4	6	8	10	12
AS	315	SA	400					
		S		160	132	90	75	40
ASR		MB		200	160	110	90	55
		M		250	200	132	110	75
ASB		ML		315	250	160	132	90
		L		400	315	200	160	110

**Type:** AS... Slip-ring rotor  
ASB... Version with brush lifting device (manual / motorized)  
ASR... 4- to 12-pole: Suitable for belt drive on request only

Rated voltage: 220 V ( $\Delta$ ) to 1000 V ( $\Delta/Y$ )  
Rated frequency: 50 Hz  
Ambient temperature: 40 °C  
Height above sea level: max. 1000 m

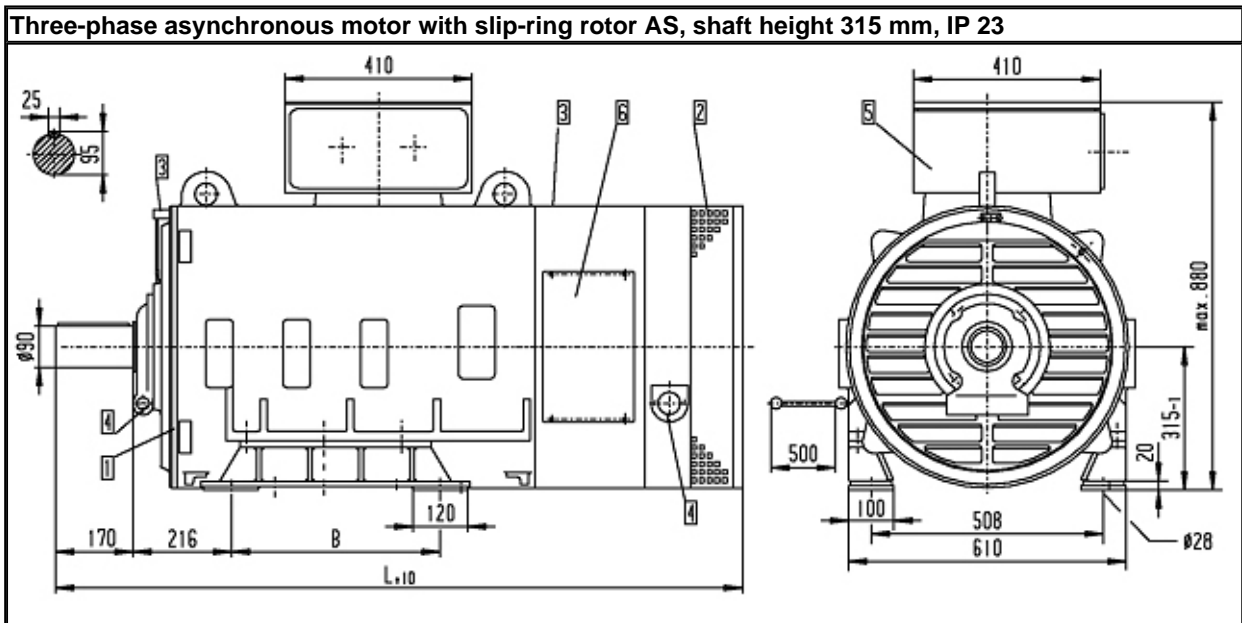

- 1 Air inlet
- 2 Air outlet
- 3 Grease nipple
- 4 Waste grease taking
- 5 Terminal box rotatable by 180°
- 6 Opening for slip-rings behind the cover

Fits:  
Shaft end m6

Type:	B	L
AS 315 S	406	1425
AS 315 MB	457	1535
AS 315 M		
AS 315 ML		
AS 315 L	508	1650

**3.2.8 Three-phase asynchronous motor with slip-ring rotor, shaft height 355 mm, degree of protection IP 23, cooling method IC 01**

Type	Frame size		Rated voltage [V]	Rated output [kW]						
	Shaft height [mm]	Length		Number of poles						
					4	6	8	10	12	
AS	355	SA	400							
		S							132	
		MA								
		M		500 <sup>1)</sup>	400 <sup>1)</sup>	250	200	160		
		ML								
ASR		L		560 <sup>1)</sup>	500 <sup>1)</sup>	315	250	200		
ASB		355	SA	6000						
			S		200	132				
			MA		250	160				
			M		315	200	132	90		
	ML									
L			400	250	160	110				

<sup>1)</sup> not suitable for brush lifting device (manual/motorized)

**Type:**

**AS... Slip-ring rotor**

**ASB... Version with brush lifting device (manual / motorized)**

**ASR... 4- to 12-pole: Suitable for belt drive on request only**

Rated voltage: 220 V (Δ) to 6600 V (Y)

Rated frequency: 50 Hz

Ambient temperature: 40 °C

Height above sea level: max. 1000 m

**Three-phase asynchronous motor with slip-ring rotor AS, shaft height 355 mm, IP 23**

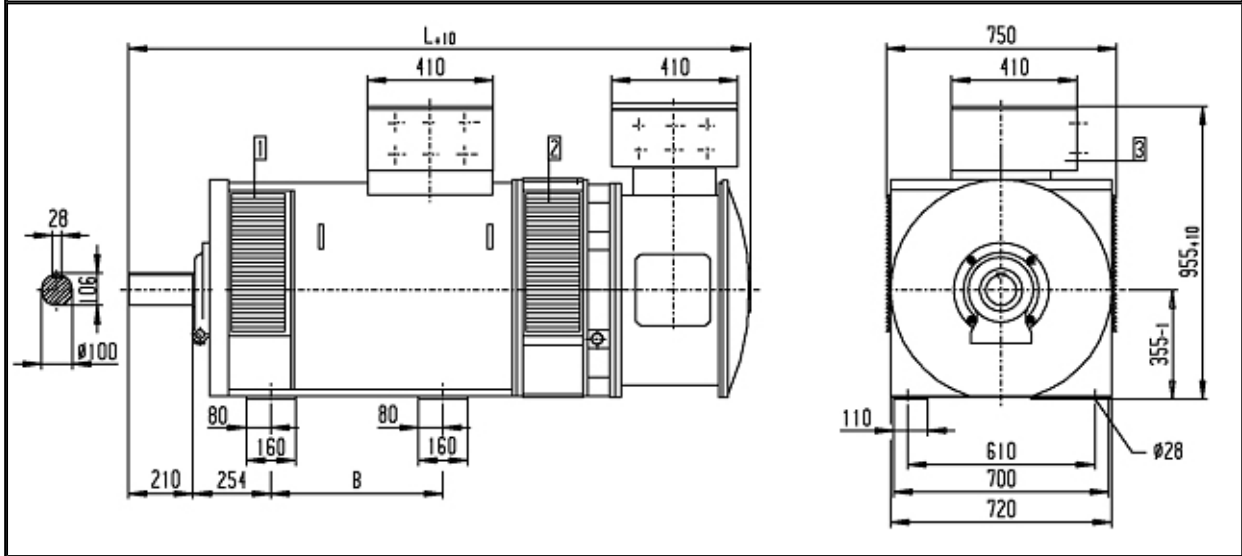

- 1 Air inlet
- 2 Air outlet
- 3 Terminal box rotatable by 180°

Fits:  
Shaft end m6

Type:	B	L
AS 355 S	on request	on request
AS 355 MA	560	
AS 355 M		
AS 355 L	630	

The drawing of the medium-voltage design motors differs with respect to the dimensions of the stator terminal box only. The following dimensions apply for all series:

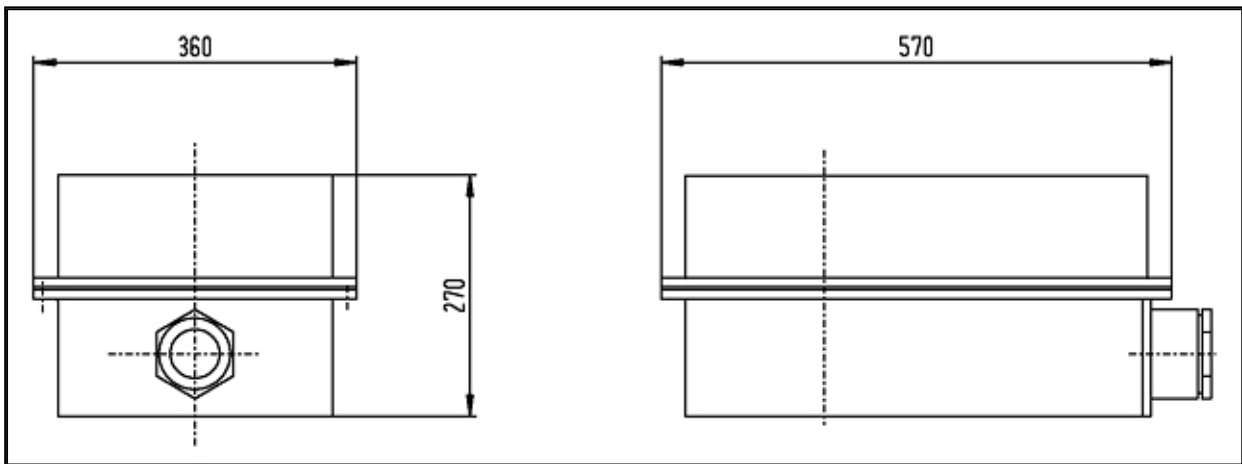

**3.2.9 Three-phase asynchronous motor with slip-ring rotor, shaft height 400 mm, degree of protection IP 23, cooling method IC 01**

Type	Frame size		Rated voltage [V]	Rated output [kW]					
	Shaft height [mm]	Length		Number of poles					
					4	6	8	10	12
AS ASR ASB	400	SA	400						
		S							
		MA		630		400	315		
		M		800	630 <sup>1)</sup>	500	400	250	
		ML							
		L		1000 <sup>1)</sup>	800 <sup>1)</sup>	630	500	315	
		SA	6000						
		S			315 <sup>1)</sup>				
		MA							
		M		500 <sup>1)</sup>	400 <sup>1)</sup>	200			
		ML							
		L		630 <sup>1)</sup>	500 <sup>1)</sup>	250	132	110	

<sup>1)</sup> not suitable for brush lifting device (manual/motorized)

**Type:** **AS... Slip-ring rotor**  
**ASB... Version with brush lifting device (manual / motorized)**  
**ASR... 4- to 12-pole: Suitable for belt drive on request only**

Rated voltage: 220 V (Δ) to 6600 V (Y)  
 Rated frequency: 50 Hz  
 Ambient temperature: 40 °C  
 Height above sea level: max. 1000 m

**Three-phase asynchronous motor with slip-ring rotor AS, shaft height 400 mm, IP 23**

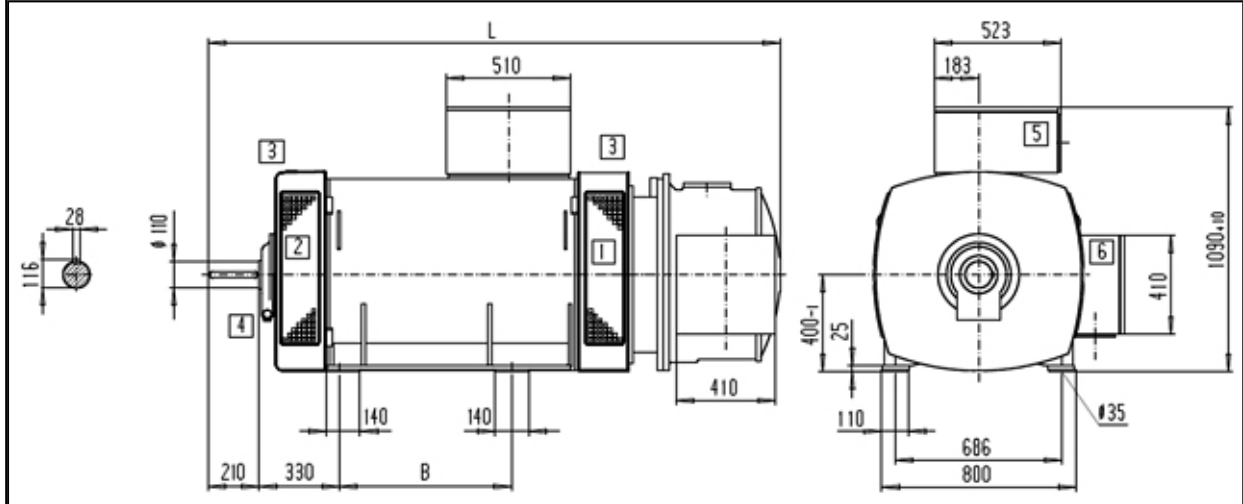

- 1 Air inlet
- 2 Air outlet
- 3 Grease nipple
- 4 Waste grease taking
- 5 Terminal box rotatable by 180°
- 6 Terminal box for rotor connection

Type:	B	L
AS 400 S	560	on request
AS 400 MA AS 400 M	630	
AS 400 L	710	

Fits:

Shaft end m6

The drawing of the medium-voltage design motors differs with respect to the dimensions of the stator terminal box only. The following dimensions apply for all series:

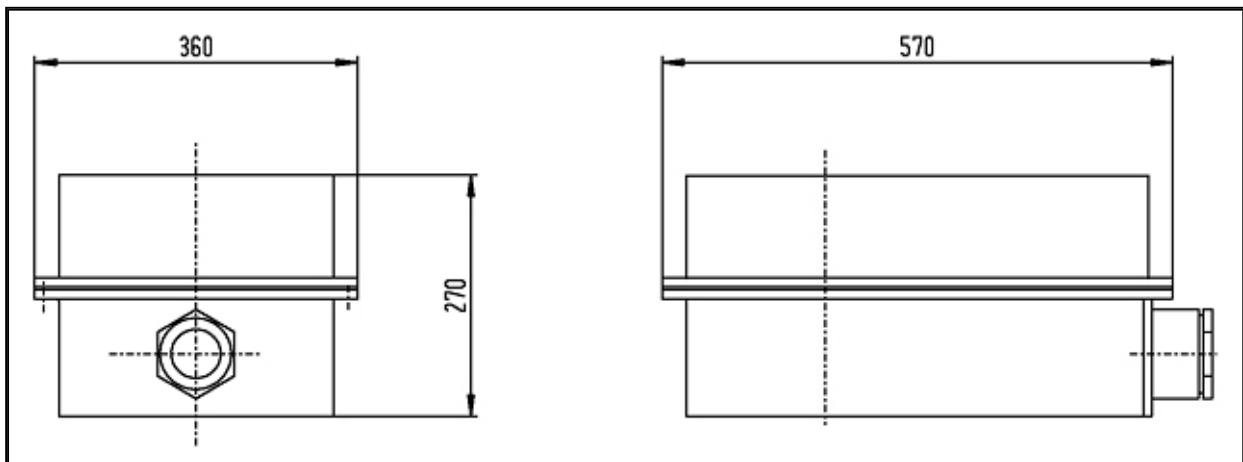

**3.2.10 Three-phase asynchronous motor with slip-ring rotor, shaft height 450 mm, degree of protection IP 23, cooling method IC 01**

Type	Frame size		Rated voltage [V]	Rated output [kW]					
	Shaft height [mm]	Length		Number of poles					
					4	6	8	10	12
AS ASR ASB	450	SA	400						
		S							
		MA							
		M		1250 <sup>1)</sup>	1000 <sup>1)</sup>			400	
		ML							
		L		1560 <sup>1)</sup>	1250 <sup>1)</sup>	800 <sup>1)</sup>	630	500	
SA		6000					160		
S			800 <sup>1)</sup>	630 <sup>1)</sup>	315	200	132		
MA					400	250	160		
M			1000 <sup>1)</sup>	800 <sup>1)</sup>	500	315	200		
ML									
L			1250 <sup>1)</sup>	1000 <sup>1)</sup>	630	400	250		

<sup>1)</sup> not suitable for brush lifting device (manual/motorized)

**Type:** **AS... Slip-ring rotor**  
**ASB... Version with brush lifting device (manual / motorized)**  
**ASR... 4- to 12-pole: Suitable for belt drive on request only**

Rated voltage: 220 V (Δ) to 6600 V (Y)  
 Rated frequency: 50 Hz  
 Ambient temperature: 40 °C  
 Height above sea level: max. 1000 m

**Three-phase asynchronous motor with slip-ring rotor AS, shaft height 450 mm, IP 23**

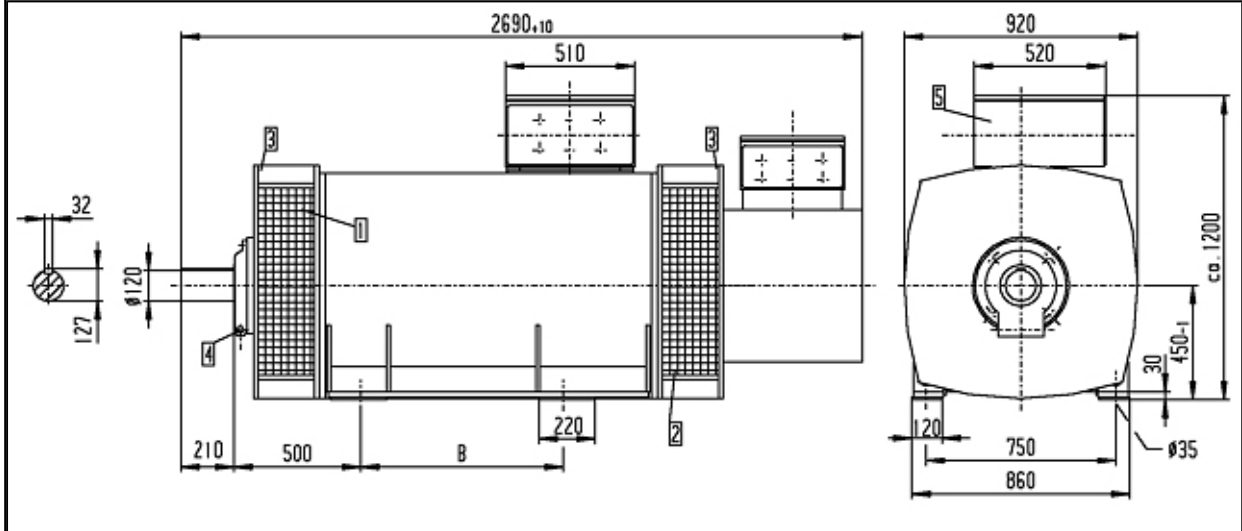

- 1 Air inlet
- 2 Air outlet
- 3 Grease nipple
- 4 Waste grease taking
- 5 Terminal box rotatable by 180°

Fits:

Shaft end m6

Type:	B
AS 450 SA	630
AS 450 S	
AS 450 MA	800
AS 450 M	
AS 450 L	

The drawing of the medium-voltage design motors differs with respect to the dimensions of the stator terminal box only. The following dimensions apply for all series:

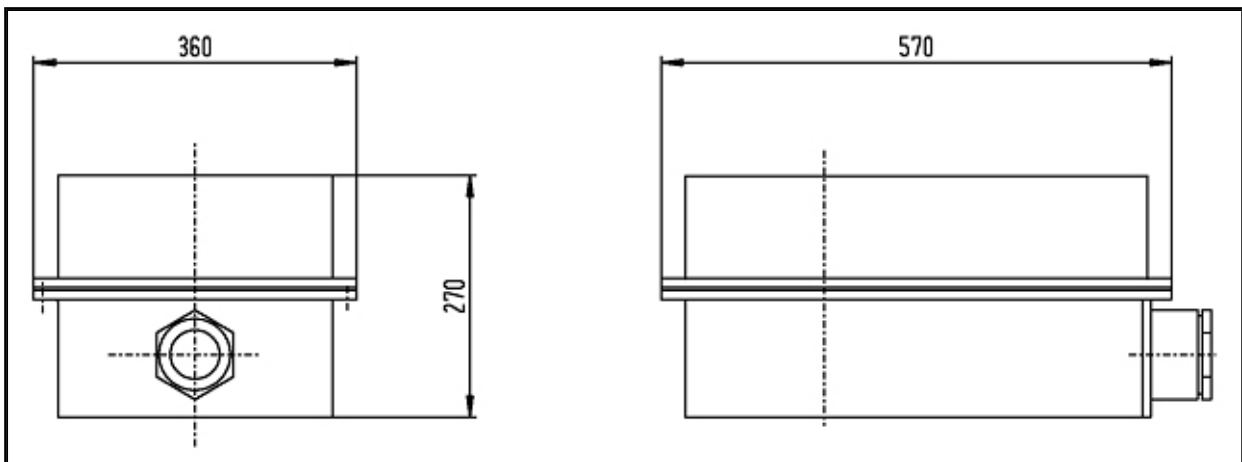

**3.2.11 Three-phase asynchronous motor with slip-ring rotor, shaft height 500 mm, degree of protection IP 23, cooling method IC 01**

Type	Frame size		Rated voltage [V]	Rated output [kW]					
	Shaft height [mm]	Length		Number of poles					
				4	6	8	10	12	
AS	500	SA	400						
		S							
		MA							
		M				1000 <sup>1)</sup>			
		ML							
		L		1700 <sup>1)</sup>	1560 <sup>1)</sup>	1250 <sup>1)</sup>	800 <sup>1)</sup>	630 <sup>1)</sup>	
ASR		SA	6000						
ASB		S							
		MA							
		M		1560 <sup>1)</sup>			315		
		ML							
		L		1750 <sup>1)</sup>	1250 <sup>1)</sup>	800	500	400	
	LL		1560 <sup>1)</sup>						

<sup>1)</sup> not suitable for brush lifting device (manual/motorized)

**Type:** **AS... Slip-ring rotor**  
**ASB... Version with brush lifting device (manual / motorized)**  
**ASR... 4- to 12-pole: Suitable for belt drive on request only**

Rated voltage: 220 V (Δ) to 6600 V (Y)  
 Rated frequency: 50 Hz  
 Ambient temperature: 40 °C  
 Height above sea level: max. 1000 m

**Three-phase asynchronous motor with slip-ring rotor AS, shaft height 500 mm, IP 23**

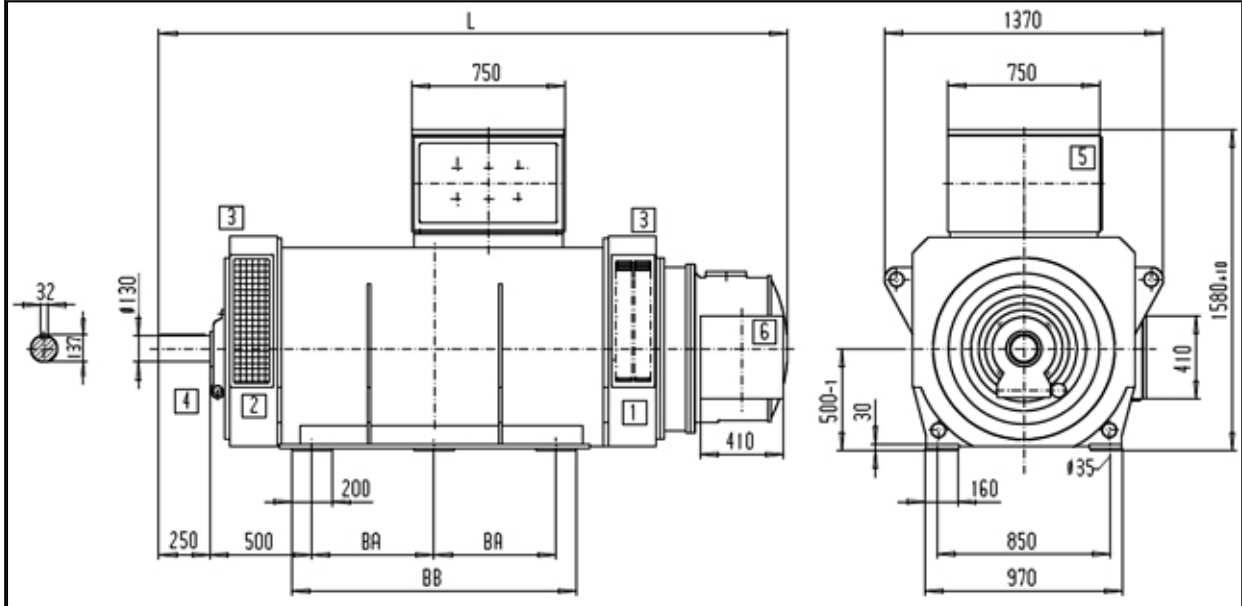

- 1 Air inlet
- 2 Air outlet
- 3 Grease nipple
- 4 Waste grease taking
- 5 Terminal box rotatable by 180°
- 6 Terminal box for rotor connection

Type:	BA	BB	L
AS 500 M	500	1200	on request
AS 500 L	600	1400	
AS 500 LL			

Fits:  
Shaft end m6

The drawing of the medium-voltage design motors differs with respect to the dimensions of the stator terminal box only. The following dimensions apply for all series:

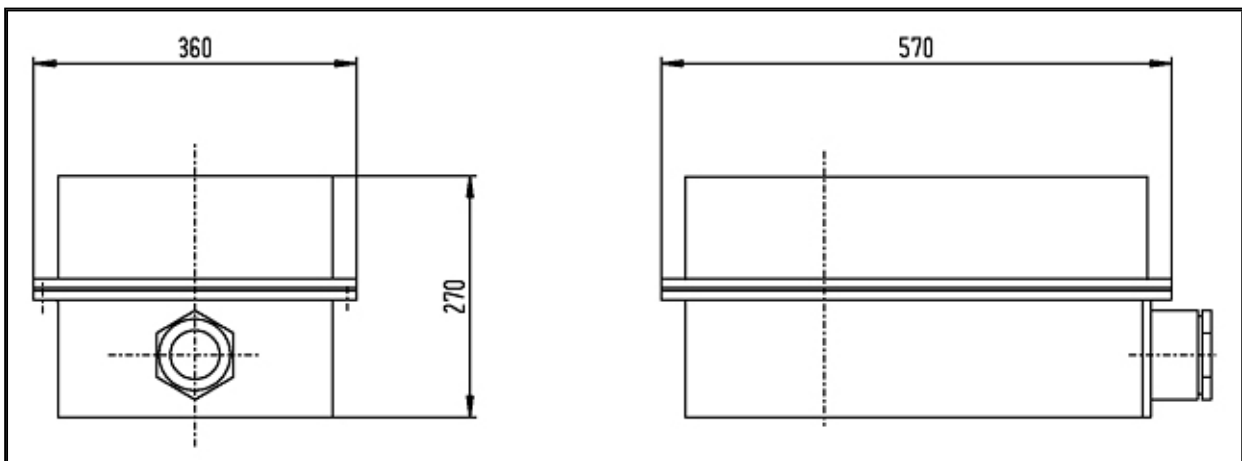

**3.2.12 Three-phase asynchronous motor with slip-ring rotor, shaft height 560 mm, degree of protection IP 23, cooling method IC 01**

Type	Frame size		Rated voltage [V]	Rated output [kW]					
	Shaft height [mm]	Length		Number of poles					
				4	6	8	10	12	
AS ASR	560	S	400						
		MA							
		M					1000 <sup>1)</sup>		
		ML							
		L				1560 <sup>1)</sup>	1250 <sup>1)</sup>	800 <sup>1)</sup>	
		LL							
ASB	560	S	6000						
		MA							
		M					630 <sup>1)</sup>	500	
		ML							
		L				1000 <sup>1)</sup>	800 <sup>1)</sup>	630	
		LL				1250 <sup>1)</sup>			

<sup>1)</sup> not suitable for brush lifting device (manual/motorized)

**Type:** **AS... Slip-ring rotor**  
**ASB... Version with brush lifting device (manual / motorized)**  
**ASR... 4- to 12-pole: Suitable for belt drive on request only**

Rated voltage: 220 V (Δ) to 6600 V (Y)  
 Rated frequency: 50 Hz  
 Ambient temperature: 40 °C  
 Height above sea level: max. 1000 m

Drawings for shaft height 560 mm are available after technical confirmation on special request only.

### 3.3 Series U (tube-cooled)

#### 3.3.1 Three-phase asynchronous motor with squirrel-cage rotor, shaft height 630 mm, degree of protection IP 55, cooling method IC 511

Type	Frame size		Rated voltage [V]	Rated output [kW]					
	Shaft height [mm]	Length		Number of poles					
				2	4	6	8	10	12
UH UK	630	SA	400		630	500	500		
		S			800	630	630	500	400
		M			1000	800	800	630	500
		L			1250	1000	1000	800	630
		LL			1560	1250			
		SA	6000		500				
		S			630	500	400	315	250
		M			800	630	500	400	315
		L			1000	800	630	500	355
		LL							

**Type:**

**UH ... Deep-bar rotor**

**UK ... Double-cage rotor**

Rated voltage:

220 V ( $\Delta$ ) to 6600 V (Y)

Rated frequency:

50 Hz

Ambient temperature:

40 °C

Height above sea level:

max. 1000 m

**Three-phase asynchronous motor with squirrel-cage rotor UH/UK, shaft height 630 mm, IP 55**

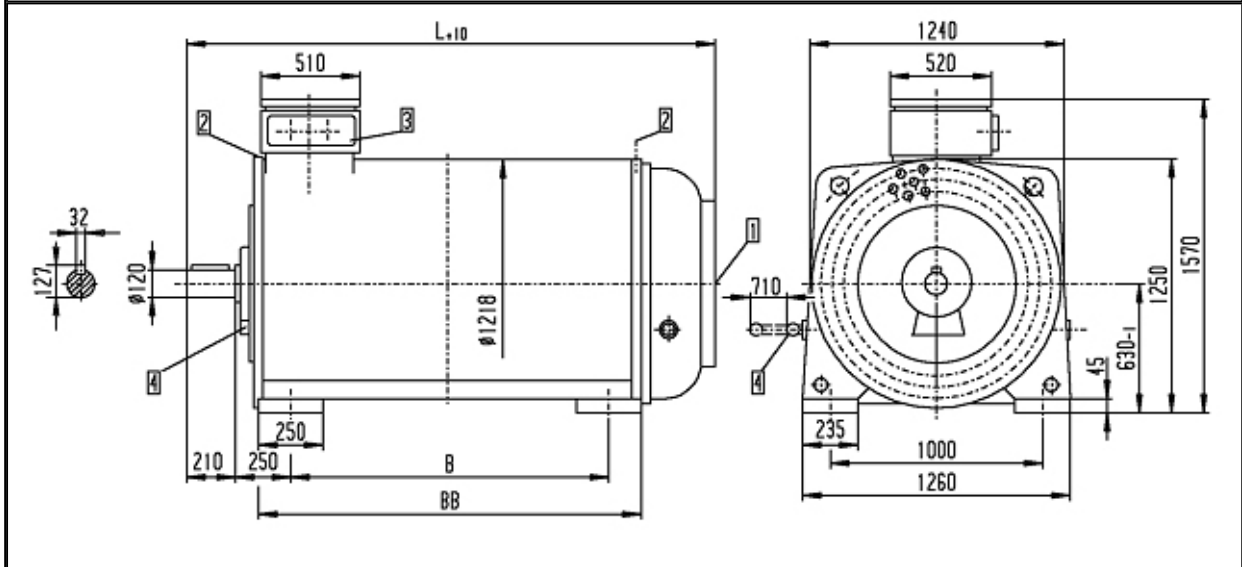

- 1 Air inlet
- 2 Grease nipple
- 3 Terminal box rotatable about 180°
- 4 Waste grease taking

Fits:  
Shaft end m6

Type:	B	BB	L
UH/UK 630 SA	on request		
UH/UK 630 S	1180	1450	2080
UH/UK 630 M	1300	1570	2200
UH/UK 630 L	1430	1700	2330
UH/UK 630 LL	1430	1700	2330

The drawing of the medium-voltage design motors differs with respect to the dimensions of the stator terminal box only. The following dimensions apply for all series:

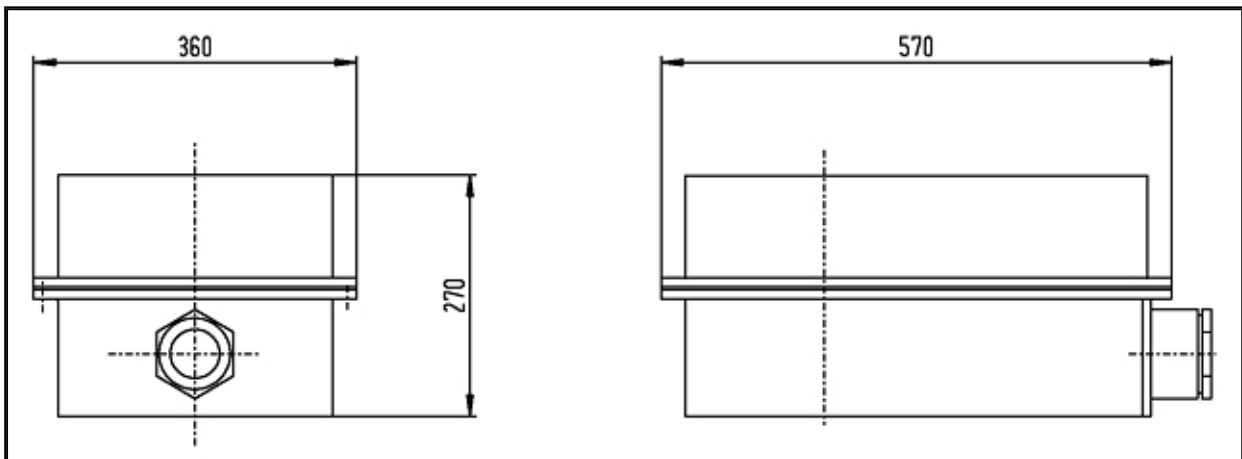

**3.3.2 Three-phase asynchronous motor with squirrel-cage rotor, shaft height 710 mm, degree of protection IP 55, cooling method IC 511**

Type	Frame size		Rated voltage [V]	Rated output [kW]					
	Shaft height [mm]	Length		Number of poles					
				2	4	6	8	10	12
UH	710	S	400						
		M			1750	1560	1250	1000	800
		L			2000	1750	1560	1120	1000
UK		S	6000			1000			400
		M			1250	1250	800	630	500
		L			1560	1400	1000	800	630

**Type:**

**UH ... Deep-bar rotor**

**UK ... Double-cage rotor**

Rated voltage:

220 V ( $\Delta$ ) to 6600 V (Y)

Rated frequency:

50 Hz

Ambient temperature:

40 °C

Height above sea level:

max. 1000 m

**Three-phase asynchronous motor with squirrel-cage rotor UH/UK shaft height 710 mm, IP 55**

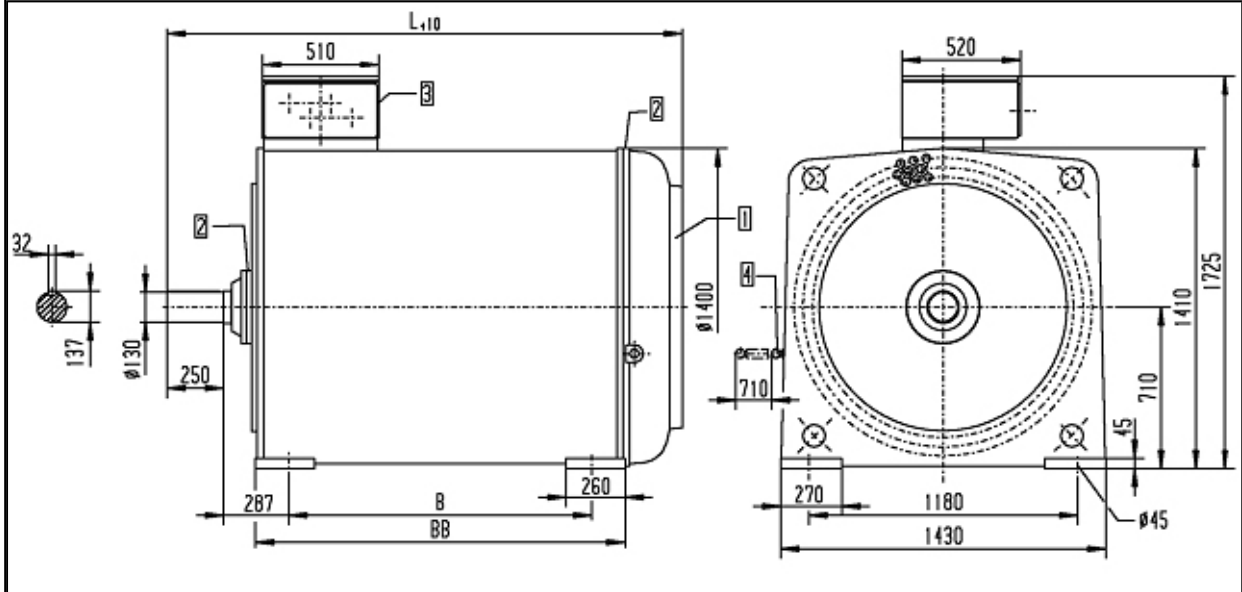

- 1 Air inlet
- 2 Grease nipple
- 3 Terminal box rotatable by 180°
- 4 Waste grease taking

Type:	B	BB	L
UH/UK 710 S	1330	1624	2330
UH/UK 710 M	1510	1804	2510
UH/UK 710 L	1510	1804	2510

Fits:

Shaft end m6

The drawing of the medium-voltage design motors differs with respect to the dimensions of the stator terminal box only. The following dimensions apply for all series:

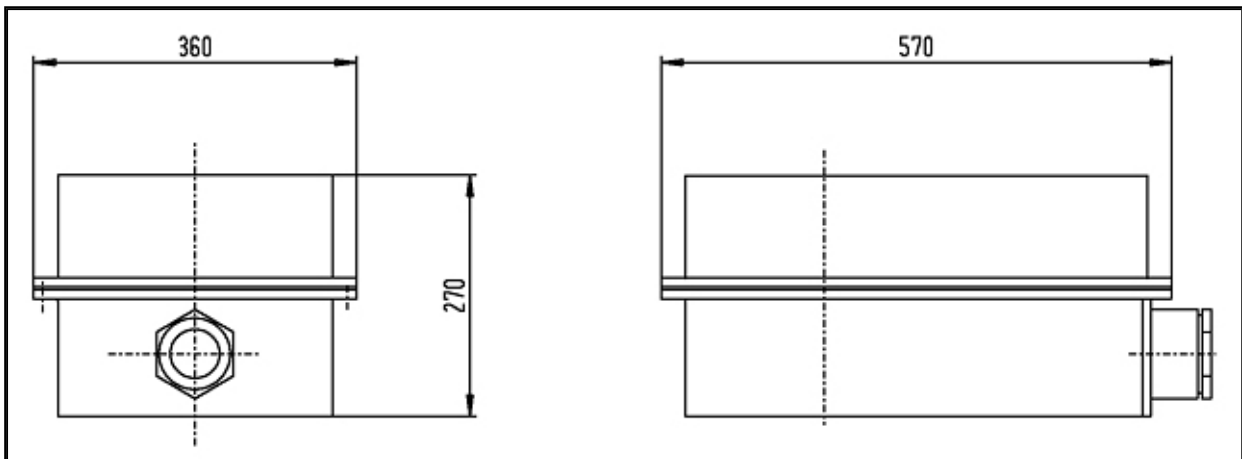

**3.3.3 Three-phase asynchronous motor with slip-ring rotor, shaft height 630 mm, degree of protection IP 55, cooling method IC 511**

Type	Frame size		Rated voltage [V]	Rated output [kW]					
	Shaft height [mm]	Length		Number of poles					
				4	6	8	10	12	
US USB	630	SA	400		630	500	400		
		S			800	630	500	400	315
		M			1000	800	630	500	400
		L			1250 <sup>1)</sup>	1000 <sup>1)</sup>	800	630	500
		LL					900 <sup>1)</sup>		
		SA	6000		500				
		S			630	500	400	315	250
		M			800	630	500	400	315
		L			1000	800	630	500	355
		LL							

<sup>1)</sup> not suitable for brush lifting device (manual/motorized)

**Type:** **US ... Slip-ring rotor**  
**USB ... Version with brush lifting device (manual / motorized)**

Rated voltage: 220 V (Δ) to 6600 V (Y)  
 Rated frequency: 50 Hz  
 Ambient temperature: 40 °C  
 Height above sea level: max. 1000 m

**Three-phase asynchronous motor with slip-ring rotor US, shaft height 630, IP 55**

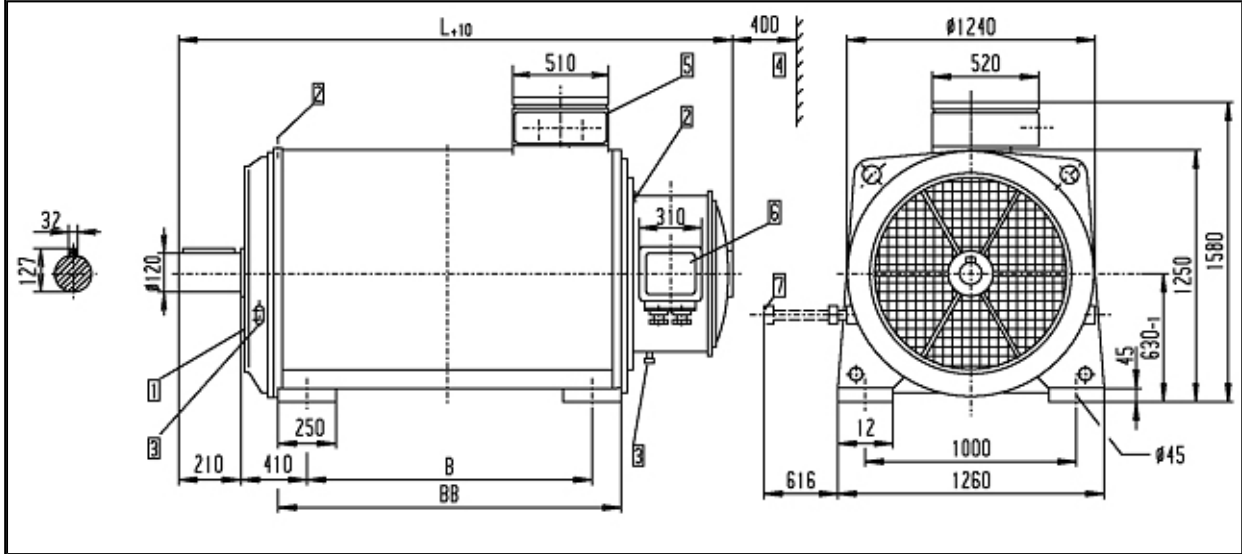

- 1 Air inlet
- 2 Grease nipple
- 3 Waste grease taking
- 4 Dismantling measure for fan cover
- 5 Terminal box rotatable by 180°
- 6 Rotor connection terminal box
- 7 Required dismantling measure selected right or left of the motor side

Type:	B	BB	L
US/USB 630 SA	on request		
US/USB 630 S	1180	1450	2490
US/USB 630 M	1300	1570	2610
US/USB 630 L	1430	1700	2740
US/USB 630 LL			

Fits:  
Shaft end m6

The drawing of the medium-voltage design motors differs with respect to the dimensions of the stator terminal box only. The following dimensions apply for all series:

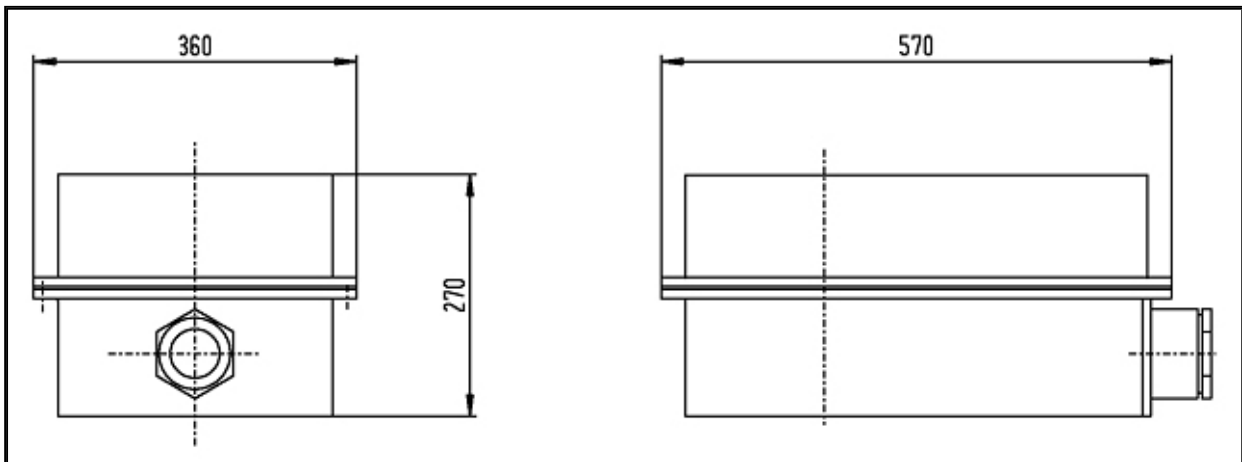

**3.3.4 Three-phase asynchronous motor with slip-ring rotor, shaft height 710 mm, degree of protection IP 55, cooling method IC 511**

Type	Frame size		Rated voltage [V]	Rated output [kW]					
	Shaft height [mm]	Length		Number of poles					
					4	6	8	10	12
US	710	S	400		1560 <sup>1)</sup>	1250 <sup>1)</sup>	1000 <sup>1)</sup>	800	630
		M			1700 <sup>1)</sup>	1560 <sup>1)</sup>	1120 <sup>1)</sup>	1000	800
		L							
USB		S	6000		1250 <sup>1)</sup>	1000 <sup>1)</sup>	800	630	400
		M			1560 <sup>1)</sup>	1250 <sup>1)</sup>	1000 <sup>1)</sup>	800	500
		L				1400 <sup>1)</sup>			

<sup>1)</sup> not suitable for brush lifting device (manual/motorized)

**Type:** **US ... Slip-ring rotor**  
**USB ... Version with brush lifting device (manual / motorized)**

Rated voltage: 220 V (Δ) to 6600 V (Y)  
 Rated frequency: 50 Hz  
 Ambient temperature: 40 °C  
 Height above sea level: max. 1000 m

**Three-phase asynchronous motor with slip-ring rotor US, shaft height 710 mm, IP 55**

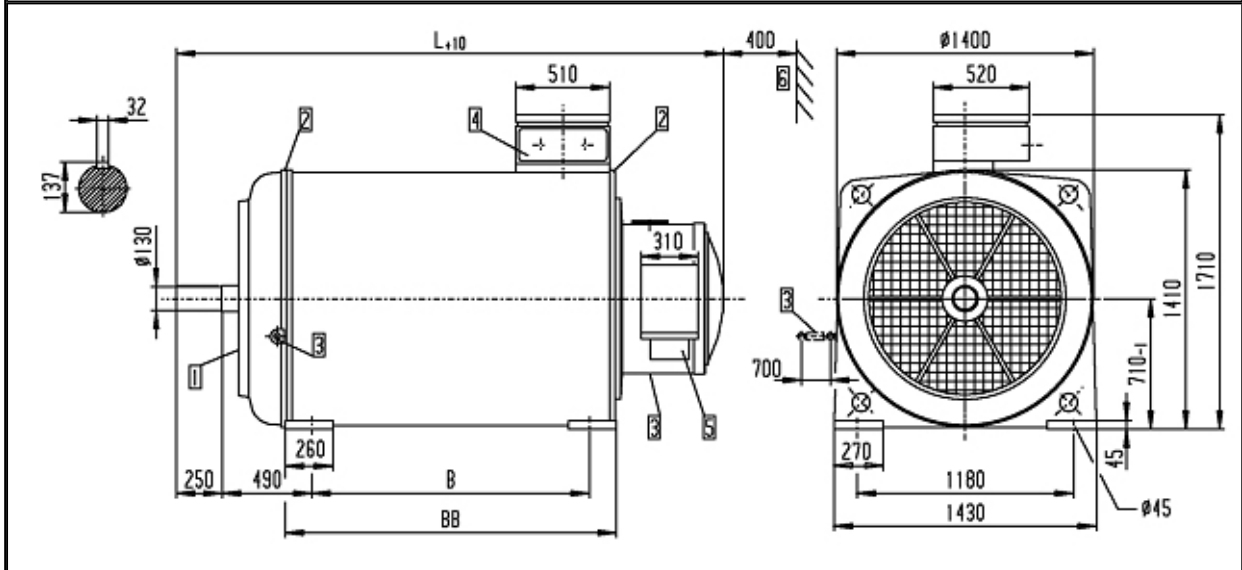

- 1 Air inlet
- 2 Grease nipple
- 3 Waste grease taking
- 4 Terminal box rotatable by 180°
- 5 Rotor connection terminal box
- 6 Dismantling measure for fan cover

Type:	B	BB	L
US/USB 710 S	1330	1624	2840
US/USB 710 M	1510	1804	3020
US/USB 710 L	1510	1804	3020

Fits:

Shaft end m6

The drawing of the medium-voltage design motors differs with respect to the dimensions of the stator terminal box only. The following dimensions apply for all series:

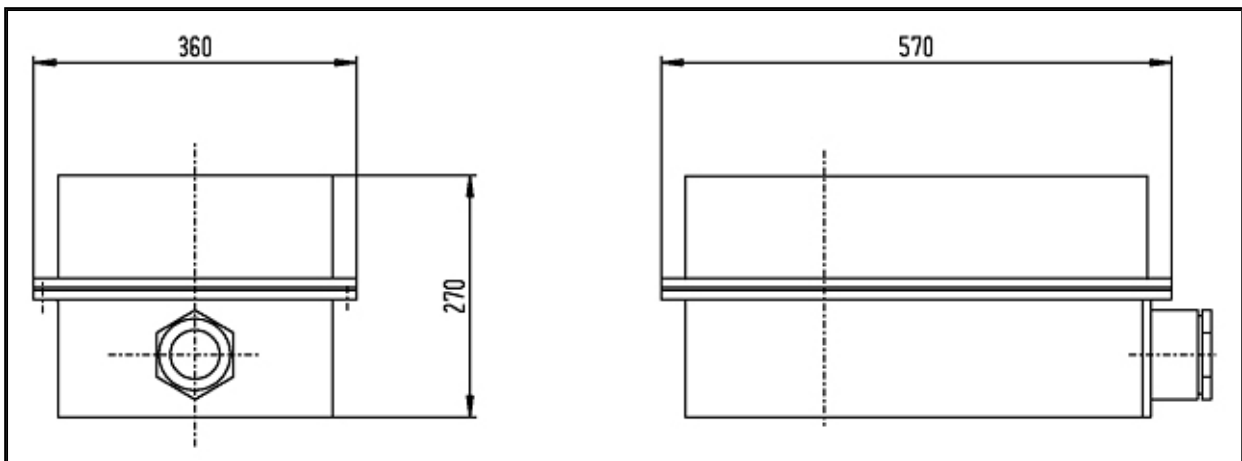

### 3.4 Series W (water-jacketed cooled)

#### 3.4.1 Three-phase asynchronous motors with squirrel-cage rotor, shaft height 315 mm, Degree of protection IP 55, cooling method IC 71W

Type	Frame size		Rated voltage [V]	Rated output [kW]					
	Shaft height [mm]	Length		Number of poles					
				2	4	6	8	10	12
WH	315	SA	400	160	132	110	90		
		S		200	160	132	110	75	50
		MB		250	200	160	132	90	60
		M		315	250	200	160	110	75
		L		400	315	250	200	132	90
WK		LL		400	315	250	200	160	110
WHR		SA	6000						
		S							
WKR		MA							
		M							
	ML								
	L								

**Type:** WH... Deep-bar rotor  
 WK... Double-cage rotor  
 WHR/WKR... 4- to 12-pole: suitable for belt drive on request only

Rated voltage: 220 V ( $\Delta$ ) to 6600 V (Y)  
 Rated frequency: 50 Hz  
 Ambient temperature: 40 °C  
 Height above sea level: max. 1000 m

**Three-phase asynchronous motor with squirrel-cage rotor WH/WK 315 S+M,  
shaft height 315 mm, IP 55**

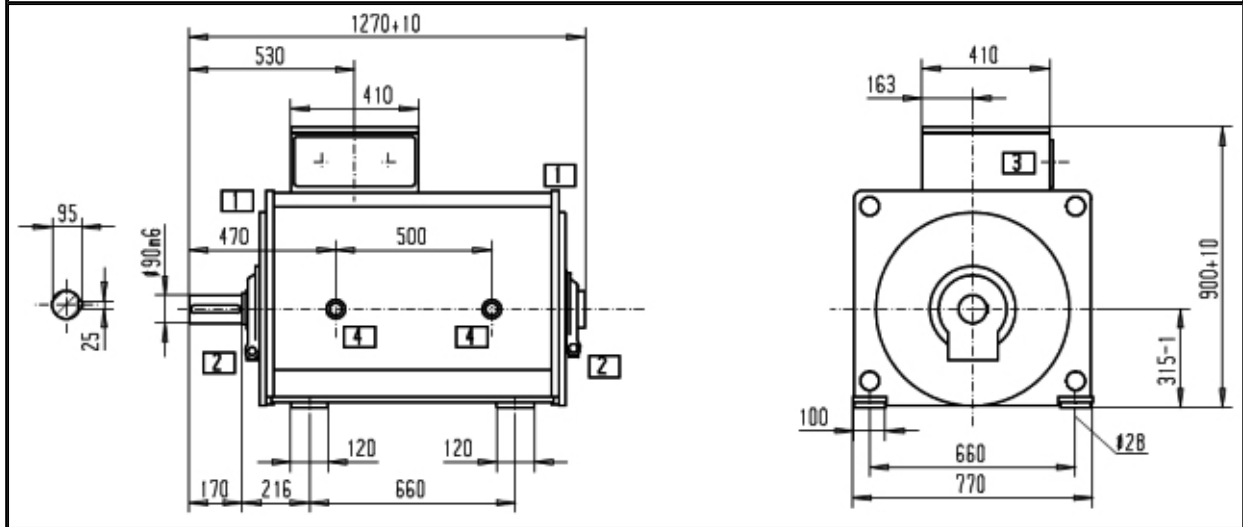

- 1 Grease nipple
- 2 Waste grease taking
- 3 Terminal box rotatable by 180°
- 4 Water in- / outlet; thread inside G 1¼"

For direct coupling only!

**Three-phase asynchronous motor with squirrel-cage rotor WH/WK 315 L,  
shaft height 315 mm, IP 55**

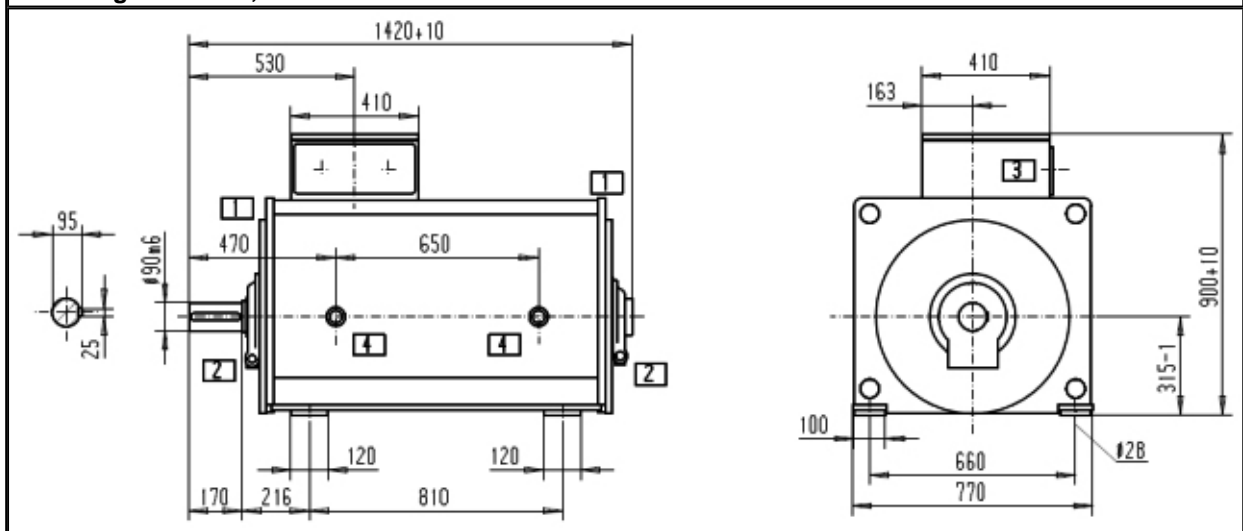

- 1 Grease nipple
- 2 Waste grease taking
- 3 Terminal box rotatable by 180°
- 4 Water in- / outlet; thread inside G 1¼"

For direct coupling only!



**Three-phase asynchronous motor with squirrel-cage rotor WH/WK 355 M+L,  
shaft height 355 mm, IP 55**

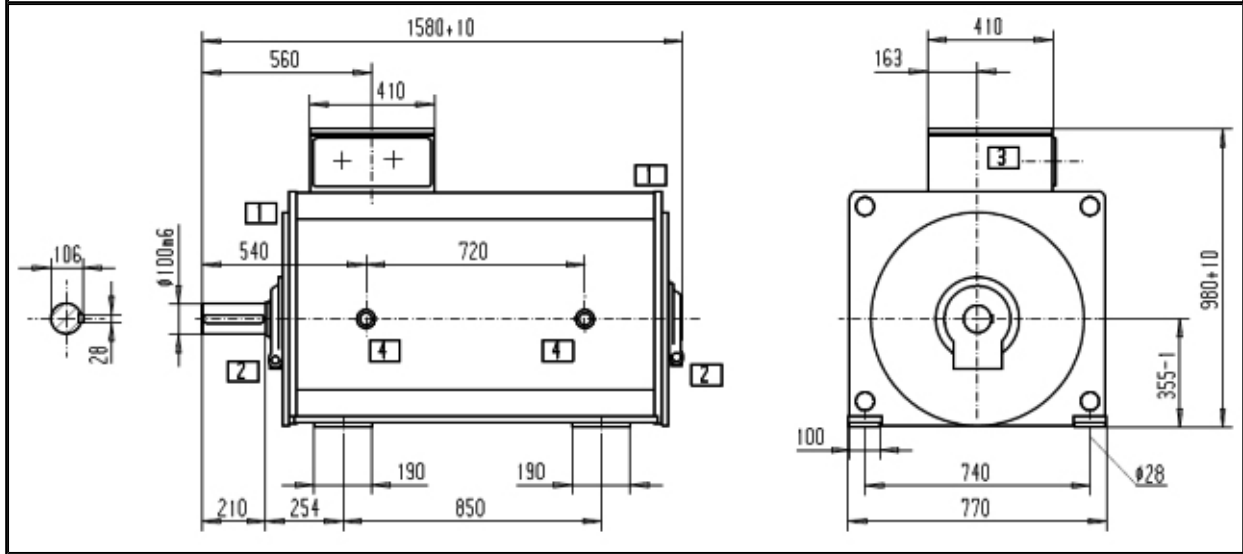

- 1 Grease nipple
- 2 Waste grease taking
- 3 Terminal box rotatable by 180°
- 4 Water in- / outlet; thread inside G 1¼"

For direct coupling only!

The drawing of the medium-voltage design motors differs with respect to the dimensions of the stator terminal box only. The following dimensions apply for all series:

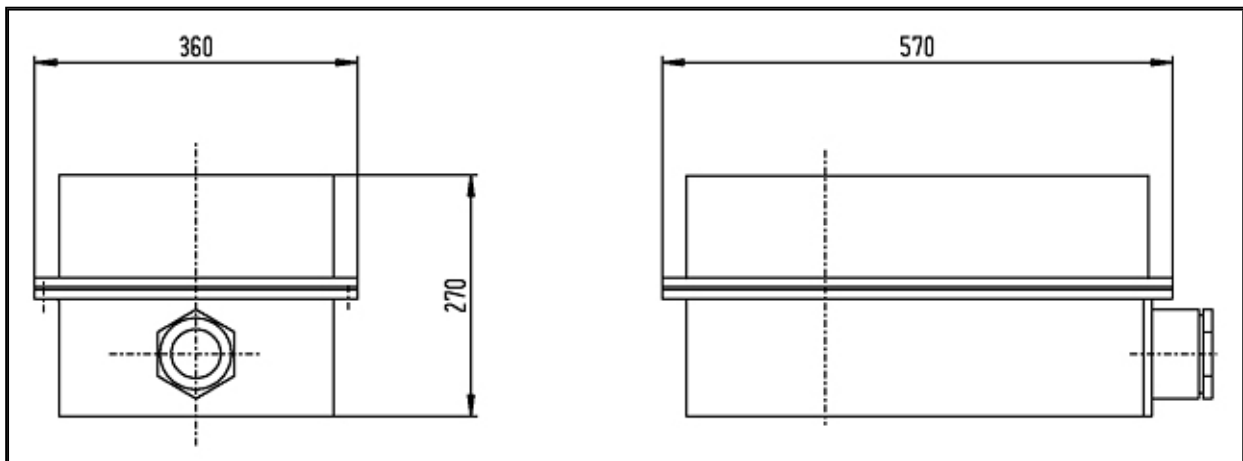

**3.4.3 Three-phase asynchronous motors with squirrel-cage rotor, shaft height 400 mm,  
Degree of protection IP 55, cooling method IC 71W**

Type	Frame size		Rated voltage [V]	Rated output [kW]					
	Shaft height [mm]	Length		Number of poles					
				2 <sup>1)</sup>	4	6	8	10	12
WH	400	S	400				400	250	200
		M			800	630	500	315	250
		L		800	1000	800	630	400	315
WK		SA	6000						
WHR		S					160		
WKR		MA			400	250	200	110	75
		M		400	500	315	250	132	90
		ML							
		L		500	630	400	315	160	110

<sup>1)</sup> available as WH only

**Type:**

**WH... Deep-bar rotor**

**WK... Double-cage rotor**

**WHR/WKR... 4- to 12-pole: suitable for belt drive on request only**

Rated voltage: 220 V (Δ) to 6600 V (Y)

Rated frequency: 50 Hz

Ambient temperature: 40 °C

Height above sea level: max. 1000 m

**Three-phase asynchronous motor with squirrel-cage rotor WH/WK 400 M+L,  
shaft height 400 mm, IP 55**

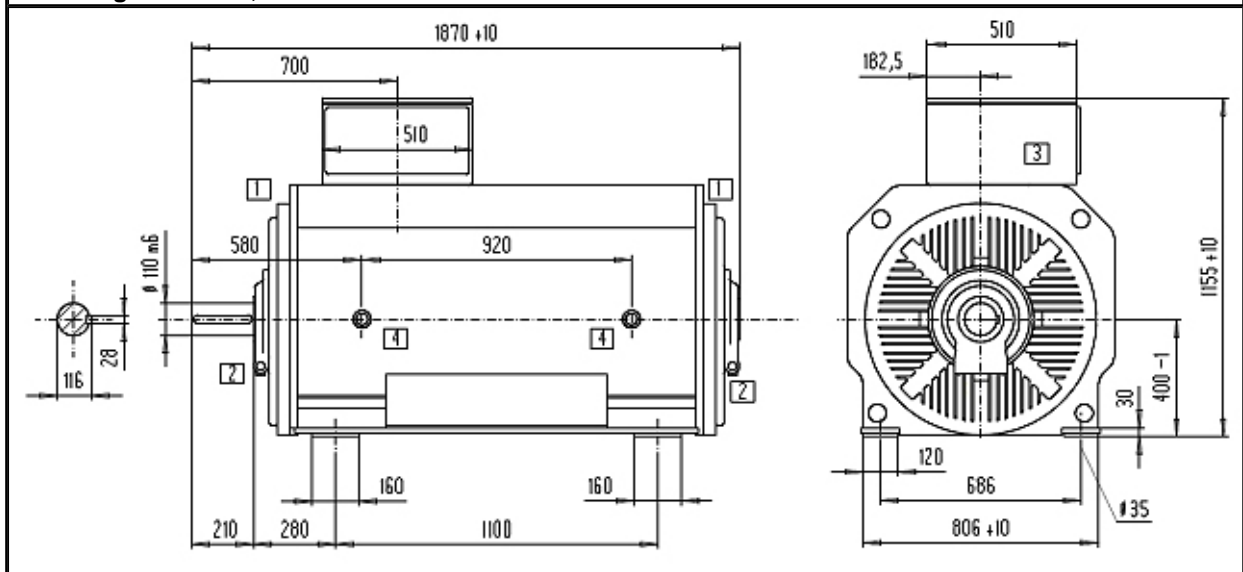

- 1 Grease nipple
- 2 Waste grease taking
- 3 Terminal box rotatable by 180°
- 4 Water in- / outlet; thread inside G 1¼"

For direct coupling only!

The drawing of the medium-voltage design motors differs with respect to the dimensions of the stator terminal box only. The following dimensions apply for all series:

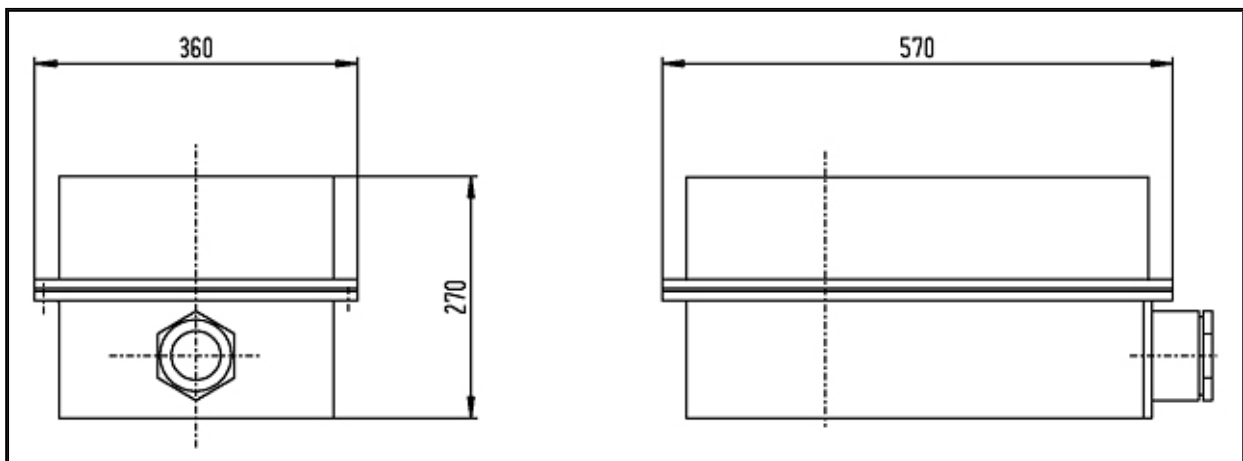



**Three-phase asynchronous motor with squirrel-cage rotor WH/WK 450 M+L,  
shaft height 450 mm, IP 55**

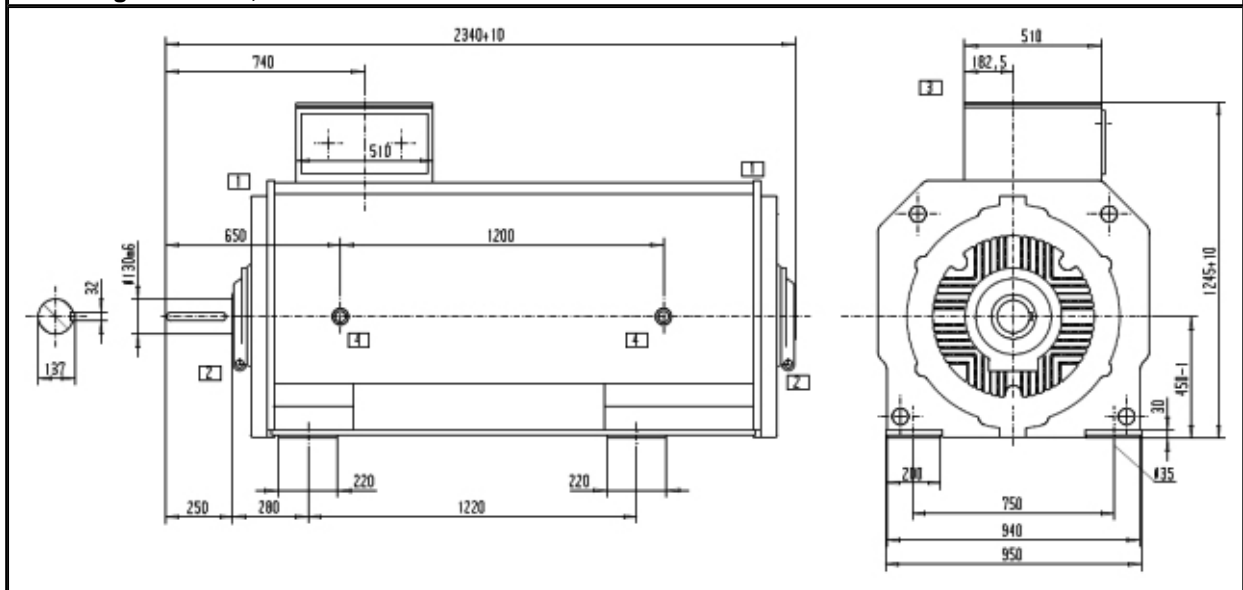

- 1 Grease nipple
- 2 Waste grease taking
- 3 Terminal box rotatable by 180°
- 4 Water in- / outlet; thread inside G 1¼"

For direct coupling only!

The drawing of the medium-voltage design motors differs with respect to the dimensions of the stator terminal box only. The following dimensions apply for all series:

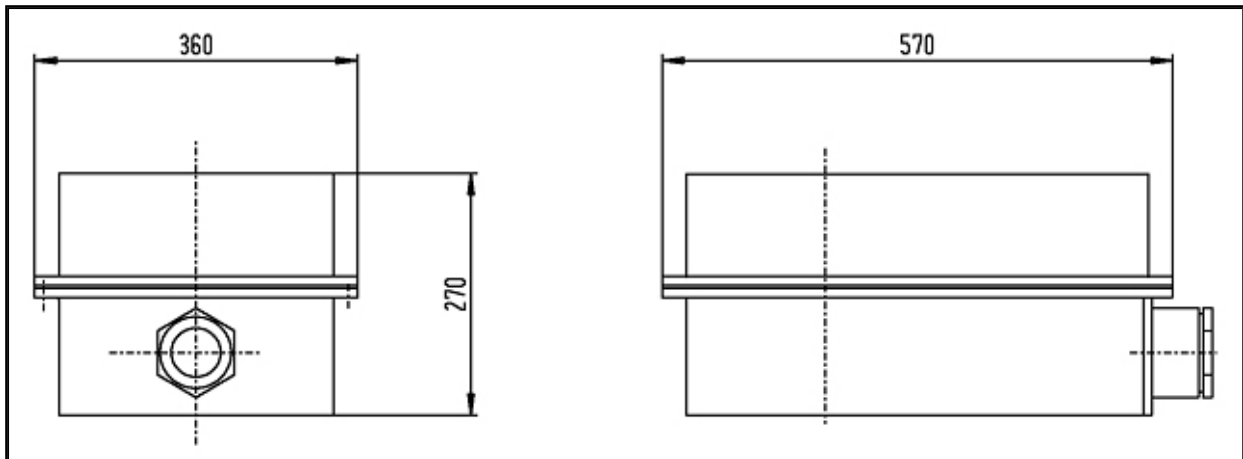

**3.4.5 Three-phase asynchronous motors with squirrel-cage rotor, shaft height 500 mm,  
Degree of protection IP 55, cooling method IC 71W**

Type	Frame size		Rated voltage [V]	Rated output [kW]					
	Shaft height [mm]	Length		Number of poles					
				2	4	6	8	10	12
WH	500	S	400						
		M			1750	1560			
		L		1)	2000	1750	1250	800	
		LL			2200	2000	1560	1000	630
WK		SA	6000						
WHR		S							
		MA							
WKR		M				800		400	250
		ML							
		L		1)		1250	1000	630	500
	LL				1560	1250	800	630	400

1) on request only

**Type:**

**WH... Deep-bar rotor**

**WK... Double-cage rotor**

**WHR/WKR... 4- to 12-pole: suitable for belt drive on request only**

Rated voltage: 220 V ( $\Delta$ ) to 6600 V (Y)

Rated frequency: 50 Hz

Ambient temperature: 40 °C

Height above sea level: max. 1000 m

**Three-phase asynchronous motor with squirrel-cage rotor WH/WK 500 M+L,  
shaft height 500 mm, IP 55**

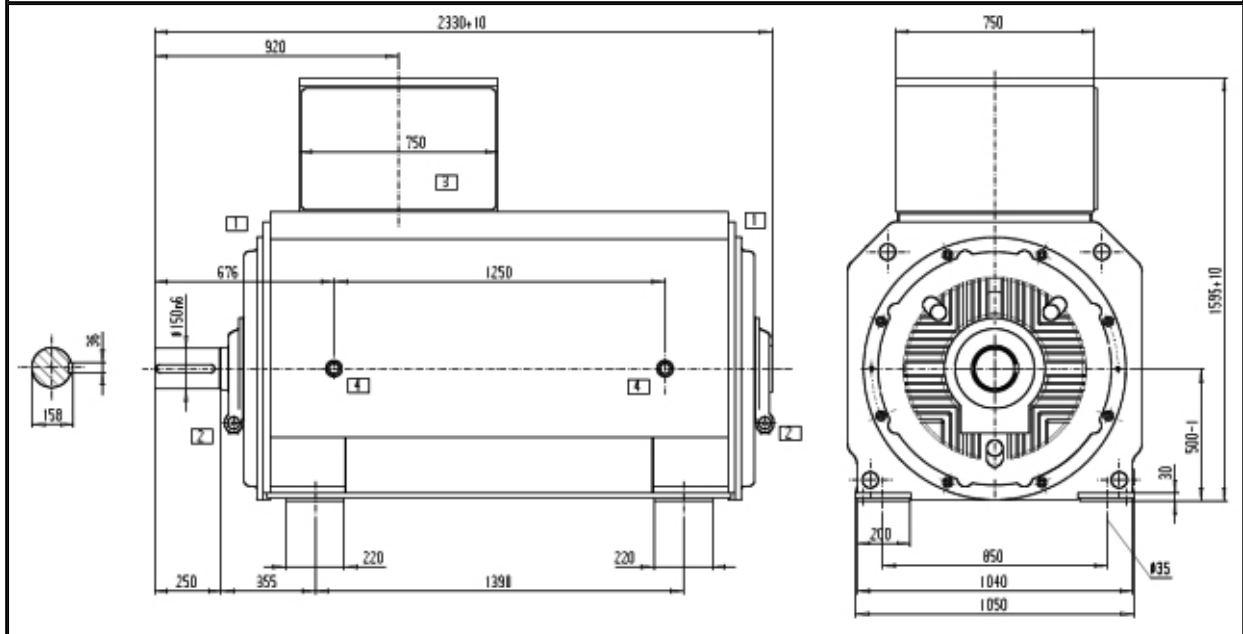

- 1 Grease nipple
- 2 Waste grease taking
- 3 Terminal box rotatable by 180°
- 4 Water in- / outlet; thread inside G 1¼"

For direct coupling only!

The drawing of the medium-voltage design motors differs with respect to the dimensions of the stator terminal box only. The following dimensions apply for all series:

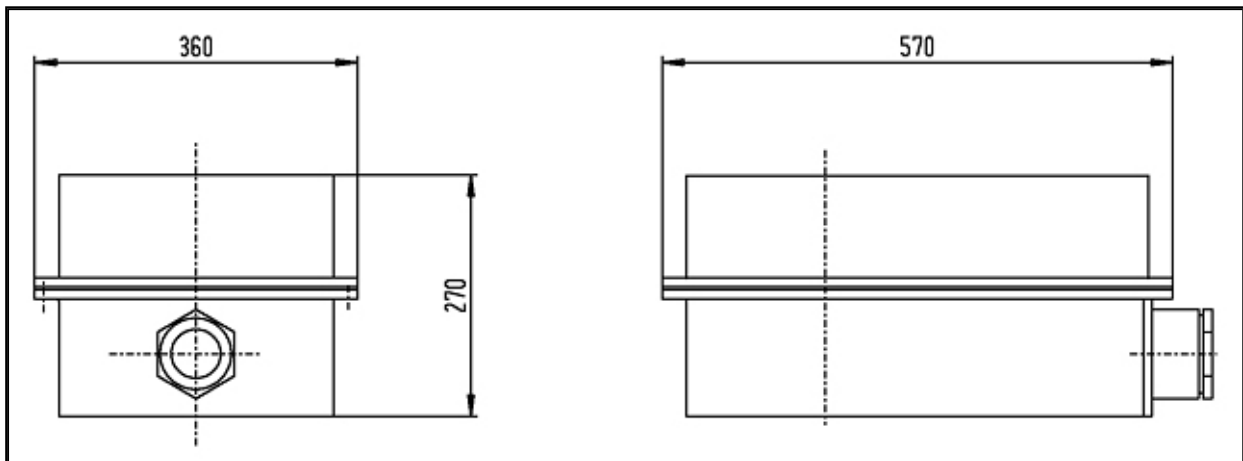

**3.4.6 Three-phase asynchronous motors with squirrel-cage rotor, shaft height 560 mm,  
Degree of protection IP 55, cooling method IC 71W**

Type	Frame size		Rated voltage [V]	Rated output [kW]						
	Shaft height [mm]	Length		Number of poles						
				2	4	6	8	10	12	
WH	560	M	400		2500 <sup>1)</sup>	2250 <sup>1)</sup>				
		L			2800 <sup>1)</sup>	2500 <sup>1)</sup>	1560	1250	800	
WK		SA	6000							
		S								
WHR		MA								
		M								
WKR		L				1750				500
		LL				2000	1560	1000	800	630

<sup>1)</sup> 500 - 690 V (Δ) only

**Type:**

**WH... Deep-bar rotor**

**WK... Double-cage rotor**

**WHR/WKR... 4- to 12-pole: suitable for belt drive on request only**

Rated voltage: 220 V (Δ) to 6600 V (Y)

Rated frequency: 50 Hz

Ambient temperature: 40 °C

Height above sea level: max. 1000 m

**Three-phase asynchronous motor with squirrel-cage rotor WH/WK 560 M+L,  
shaft height 560 mm, IP 55**

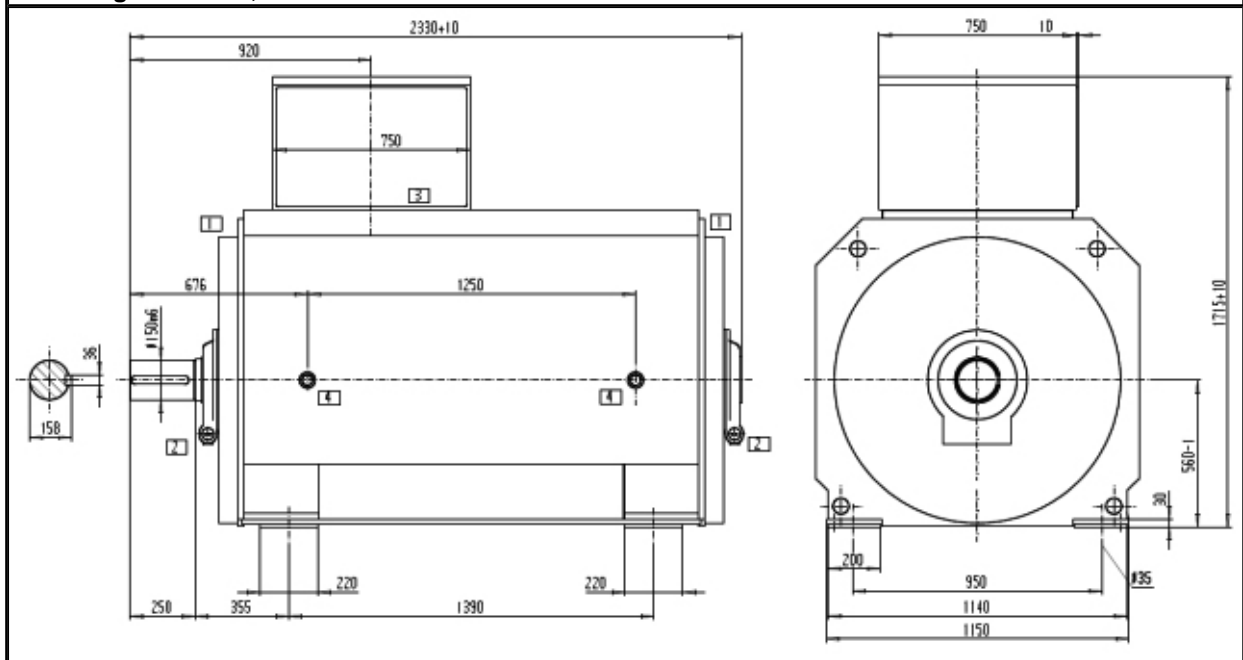

- 1 Grease nipple
- 2 Waste grease taking
- 3 Terminal box rotatable by 180°
- 4 Water in- / outlet; thread inside G 1 1/4"

For direct coupling only!

The drawing of the medium-voltage design motors differs with respect to the dimensions of the stator terminal box only. The following dimensions apply for all series:

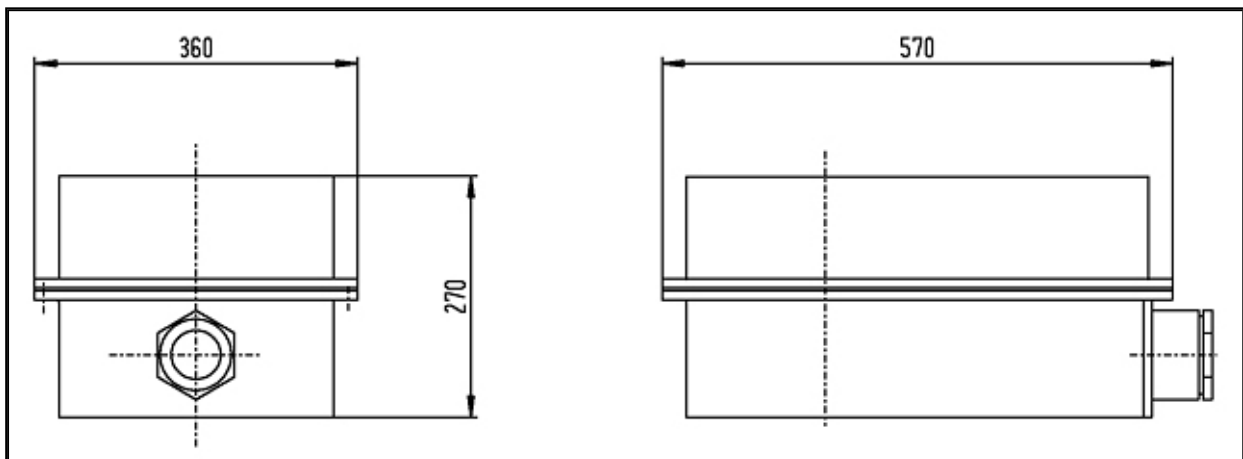

#### 4 Delivery and performance programme

- **Three-phase synchronous generators**

Low voltage and medium voltage up to 6900 V,  
4- to 16-pole, 250 - 4200 kVA, IP 23

- **Asynchronous generators on request**

- **Three-phase asynchronous motors** - Low voltage up to 1000 V

**Squirrel-cage rotors, 2- to 12-pole**

surface ventilated	200 - 2000 kW <sup>1)</sup>	IP 55
tube-cooled	630 - 2000 kW <sup>1)</sup>	IP 55
open-circuit ventilated	160 - 3500 kW <sup>1)</sup>	IP 23
water-jacketed cooled	132 - 2800 kW <sup>1)</sup>	IP 55

**Slip-ring rotors<sup>2)</sup>, 4- to 12-pole**

surface ventilated	200 - 1000 kW <sup>1)</sup>	IP 55
tube-cooled	630 - 1700 kW <sup>1)</sup>	IP 55
open-circuit ventilated	160 - 1700 kW <sup>1)</sup>	IP 23

- **Three-phase asynchronous motors** - Medium voltage up to 6600 V

**Squirrel-cage rotors, 2- to 12-pole**

surface ventilated	132 - 1400 kW <sup>1)</sup>	IP 55
tube-cooled	500 - 1560 kW <sup>1)</sup>	IP 55
open-circuit ventilated	200 - 2800 kW <sup>1)</sup>	IP 23
water-jacketed cooled	132 - 2000 kW <sup>1)</sup>	IP 55

**Slip-ring rotors<sup>2)</sup>, 4- to 12-pole**

surface ventilated	110 - 1000 kW <sup>1)</sup>	IP 55
tube-cooled	500 - 1560 kW <sup>1)</sup>	IP 55
open-circuit ventilated	200 - 1750 kW <sup>1)</sup>	IP 23

- **Special machines and modifications**

in a.m. power range on request

- **Submersible motors on customer's request**

- **Rotating converters**

<sup>1)</sup> All power values related to the 4-pole version (1500 rpm)

<sup>2)</sup> Water-jacketed cooled slip-ring rotors on request